

# STRATA 2

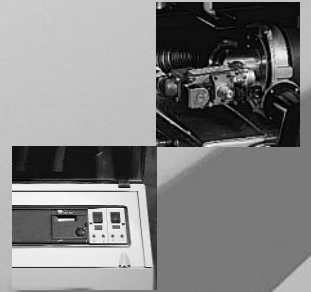

**GAS FIRED HIGH EFFICIENCY/  
CONDENSING ULTRA LOW NO<sub>x</sub> BOILER  
SINGLE UNIT OUTPUT 120kW  
INSTRUCTIONS FOR INSTALLATION,  
SERVICING & OPERATION**



**MHS**  
BOILERS

## Index

<b>page</b>	<b>section</b>		<b>page</b>	<b>section</b>	
<b>3</b>	<b>1.0</b>	General	<b>25</b>	<b>5.8.2</b>	Boiler Manager RVA 47 Installation Procedure (Normally Factory Fitted)
	<b>1.1</b>	Product Description			
	<b>1.2</b>	Certification Details			
<b>3-5</b>	<b>2.0</b>	Product Description	<b>26</b>	<b>5.8.3</b>	Mixing Valve Controller RVA 46 Installation Procedure
<b>6</b>	<b>3.0</b>	Technical Details		<b>5.9</b>	Connecting a Condensate Pump
	<b>3.1</b>	Technical Data			
<b>7</b>	<b>3.2</b>	Critical Dimensions	<b>27</b>	<b>5.9.1</b>	Condensate Receptacle and Pump - Model No. KHPI
<b>8</b>	<b>3.3</b>	System Guidance		<b>6.0</b>	Commissioning and Testing
	<b>3.4</b>	Flue Options		<b>6.1</b>	Filling the Boiler
	<b>4.0</b>	Appliance Installation Requirements	<b>28</b>	<b>6.2</b>	Appliance Operation Left Switch Panel
	<b>4.1</b>	Statutory Requirements		<b>6.2.1</b>	Left Switch Panel
<b>8-9</b>	<b>4.2</b>	Boiler Position		<b>6.2.2</b>	Module Control Panels
<b>9-15</b>	<b>4.3</b>	Flue Options & Terminal Position	<b>29</b>	<b>6.2.3</b>	DIP Switches
<b>15</b>	<b>4.4</b>	Ventilation Requirements	<b>30</b>	<b>6.3</b>	Firing the Appliance
<b>16-17</b>	<b>4.5</b>	Hydraulic System Design		<b>6.3.1</b>	Initial Start Up
<b>17</b>	<b>4.6</b>	Gas Supply		<b>6.4</b>	Setting and Adjusting the Load
	<b>4.7</b>	Electrical Supply	<b>31</b>	<b>6.4.1</b>	Setting Minimum Load
<b>18</b>	<b>5.0</b>	Installation Instructions		<b>6.4.2</b>	Setting Maximum Load
	<b>5.1</b>	Unpacking the Boiler		<b>6.4.3</b>	Setting Maximum/Minimum Load for Upper Module
	<b>5.2</b>	Positioning the Boiler		<b>6.5</b>	Setting for Propane Gas
	<b>5.3</b>	Air Supply & Exhaust Connections	<b>32</b>	<b>6.6</b>	Setting Domestic Hot Water
	<b>5.4</b>	Gas Connection		<b>6.7</b>	Switching Off the Appliance
<b>19</b>	<b>5.5</b>	Water Connections		<b>7.0</b>	Boiler Control Settings
	<b>5.6</b>	Condense Waste Connections	<b>32-33</b>	<b>7.1</b>	End User Parameter Settings
	<b>5.7</b>	Electrical Connections - General	<b>33-36</b>	<b>7.2</b>	Heating Engineer Parameter Setting
	<b>5.7.1</b>	Connecting the Power Supply	<b>37-38</b>	<b>7.3</b>	OEM Parameter Setting
<b>20</b>	<b>5.7.2</b>	Connecting of System Safety Interlocks	<b>38</b>	<b>8.0</b>	Maintenance and Inspection
<b>20-23</b>	<b>5.7.3</b>	Connecting of System Safety Interlocks Connection Diagrams		<b>8.1</b>	Inspection
<b>24</b>	<b>5.7.4</b>	Electrical Wiring Diagrams	<b>39</b>	<b>8.2</b>	Maintenance
<b>25</b>	<b>5.7.5</b>	Connecting Remote Fault Alarms		<b>9.0</b>	Fault Diagnosis
	<b>5.8</b>	Connecting Additional Boilers		<b>9.1</b>	Control Panel
	<b>5.8.1</b>	Connecting Third, Fourth, Fifth, Sixth, Seventh and Eighth Units	<b>39-40</b>	<b>9.1.1</b>	Operation Indicator
				<b>9.1.2</b>	Fault Indicator
			<b>41</b>	<b>9.1.3</b>	System Faults
				<b>9.2</b>	RVA 47 Fault Indication
<b>42</b>	<b>10.0</b>	Parts List			
	<b>11.0</b>	Guarantees			

## 1.0 general

### 1.1 general notes

These instructions are intended to assist the installer, commissioning engineer, maintenance engineer and user with the installation, maintenance and usage of the Strata 2-120 gas fired condensing boiler.

Please read this manual fully before commencing the installation of the appliance. MHS Boilers Ltd shall not be responsible for any damage resulting from failure to carefully observe the instructions given.

The Strata 2-120 must only be installed by persons deemed to be competent i.e. Corgi Registered. This manual must be handed to the user following completion of the installation.

### 1.2 certification details

The Strata 120-2 complies with all relevant European Directives and has been independently certified to comply with the requirements of prEN 483 for use in GB and IE with Gas Category I12H3P.

(Natural gas G20 @ 20 mbar inlet pressure).

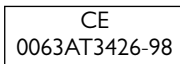

The flue classification (depending upon the required flue option) is either B23; C13X; C33X; C43X; C53X; C63X; C83X.

## 2.0 product *description*

The Strata 2-120 boiler is a gas-fired, fully condensing floor standing appliance with a fully modulating output of 12.2 to 119.7 kW at 30°C return water temperature. The appliance may be used singularly or in multiples serving the needs of LTHW systems up to a maximum flow temperature of 85°C.

Each Strata 2-120 boiler incorporates two modules, each module accommodates its own burner, combustion fan, gas valve, ignition/ionisation, electrode and burner control with safety circuits.

Each module contributes 50% of the total output, and can be operated independently. Each heat exchanger has a modulating capacity of 20% to 100%. If a fault should occur with one of the burner/heat exchanger modules, the other will continue to operate.

The boiler includes, as standard, matched modulating speed pumps which automatically adjust the primary flow rate for the heat exchangers to (where possible) maintain the design temperature difference. The pumps have residual duty to convey the boiler mass flow rate to the installers system low loss manifold, ensuring correct flow rates through the boiler at all times and reduces installer involvement in this critical area.

The Strata 2-120 incorporates comprehensive microprocessor controls. A RVA47 (CLI) cascade manager is used to translate the heat demand of the installation into a boiler load for each module. The first RVA47 (CLI) manager has the potential to control up to four modules (burner/heat exchangers) in modulating/cascading fashion. Therefore when installing Strata 2-120 boiler in twin form, all serving the same system, an RVA47 (CLI) controller is only required and supplied in the first boiler.

The RVA47 (CLI) controller in boiler no.1 is always the 'master' and every subsequent controller must be set as a 'slave'.

In addition to the RVA47 (CLI) controller, each Strata 2-120 boiler incorporates individual burner/heat exchanger safety controls which provide the essential safety functions of burner ignition and flame monitoring, overheat cut off devices for excessive water or flue gas temperature, an LCD display screen to indicate run or fault status codes, and individual burner on/off switches.

### Room Sealed Option

When required, the Strata 2-120 boiler, may be installed as a room sealed appliance, taking air for combustion from outside the building. This option is recommended for installations where air from within the building may be contaminated with oxidising agents, which occur in appliances such as swimming pool plant rooms, dry cleaners and in various manufacturing and industrial process environments etc.

## 2.0 product description (contd)

### Extended Flue Lengths and Difficult Flue Routes

The excess fan pressure from the combustion system is in the order of 100Pa which allows the appliance to be exhausted using small diameter flue components over long distances or awkward routes, which allows a considerable degree of flexibility in boiler siting.

As the efficiency of this unit is extremely high, high grade plastic flue components can be utilised because the temperature of the flue gas will at all times remain below 80°C. (To protect the plastic discharge pipe against excessive temperatures, a safety thermostat is employed set at 80°C, which is fitted inside the plastic discharge pipe in the unit, immediately above the upper heat exchanger).

**Note:** These flue components are available exclusively from MHS.

The Strata 2-120 includes a wealth of enhanced operating facilities and features as standard:

- **Floor mounted with compact dimensions** (provides maximum heat from a minimal footprint).
- **Fully modulating heat output:** The output is fully variable across the twin burner/heat exchanger arrangement providing a 10:1 turn down ratio, sliding between 10% and 100% of output which automatically and instantly adjusts to meet the needs of the system. The percentage of power at any given time may be dictated by flow temperature, outside air temperature, room temperature, stored domestic hot water temperature or a combination of these.
- **Fully condensing stainless steel heat exchanger.** The Strata 2-120 boiler features a heat exchanger which deliver exceptional heat transfer, and is fabricated from corrosion resistant, long life, stainless steel. The uniquely designed SpiranoX heat exchanger will return operating efficiencies of up to 105% nett (95.5% gross) with a return water temperature of 30°C.
- **Extremely low harmful emissions.** The boiler utilises 100% premixed gas/air fed at positive pressure to the metal fibre sheathed radiant burners. The optimum amount of gas/air is mixed before the combustion fan, and then blown into the burner.
- **Single/double heat exchanger operation for maximum flexibility of operation.** A spring loaded non-return valve has been fitted in the air intake to the combustion fan, preventing flue gases from a firing module from entering the air intake of the non firing module. Also a hydraulic non-return valve is fitted in each heat exchanger return pipe to prevent circulation of water if one of the heat exchangers is not functioning.
- **Low CO and NOx emissions.** The advanced burner and controls allows extremely clean and efficient combustion to be achieved, which in turn gives extremely low emissions certified in accordance with DIN 4702, CO 15mg/kWh (14ppm) – Nox 11mg/kWh (8.0ppm).
- **Accurate variable burner output control.** The premix fans have very accurate speed control which allows precise control over combustion air volumes. This system facilitates great accuracy and instantly provides variable burner output. The nature of the variable rate fans allows, in the case of a lower heat demand, the fan to run at a slower speed, resulting in lower power consumption.
- Each boiler incorporates LCD display screens to display current operational status and operational parameters. Each RVA controller provides cascade modulating burner output control, hours run counters for each burner and programmable lead/lag sequencing.

## 2.0 product description (contd)

- The 'master' RVA47 (CLI) controller provides:
  - Overall modulating output in accordance with the demands of the system.
  - Inbuilt weather compensation giving direct-on-boiler VT control if required.
  - Remote stored domestic hot water temperature control
  - Domestic hot water primary pump or diverter valve control. (2 Amps max)
  - Heating system pump control. (2 Amps max)
  - Inbuilt heating system time control with 35 on and 35 off programmable set points within 7 days.
  - Inbuilt DHW time control with 3 on and 3 off sets points per day.
  - An option to control the boiler/s from external 0-10V input, or volt free switching.
  - Programmable frost protection.
  - The additional option to connect remote control devices.
  - The additional option to connect VT zone controllers. (RVA46)

### Designed for Ease of Maintenance

The appliance has been designed and engineered to be easy to maintain, with most major service operations being quick and easy to complete with the minimum of tools.

Each module can operate independently, without affecting the service of the other modules within the system.

To facilitate the annual inspection and cleaning of the syphon, there is a rinsing pipe at the back of the unit. The condense is led through a built-in syphon to a plastic connection at the back, where a suitable connection can be made to the termination point.

### Operational Data Logging

Each burner assembly has a data logging facility to record operational actions, which can be accessed via an RS232 communication from a PC. This facility provides a useful service tool as it allows a record of operation to be viewed and any faults to be identified.

## 3.0 technical details

### 3.1 technical data

Table 1

Model Strata 2		Single 120	Multiple Boilers 240      360		Multiple Boilers 480      600		
No. of Boilers		1	2	3	4	5	
No. of Burners/ Ht Exchangers		2	4	6	8	10	
No. of Cascade RVA Controllers Master & Slaves		1 master	1 master	1 master + 1 Slave	1 master + 2 Slave	1 master + 3 Slave	
Output Turn Down Ratio		10:1	20:1	30:1	40:1	50:1	
Heat Output at 80°C Flow - 60°C Return	Max	kW	107.8	215.6	323.4	431.2	539
	Min		11.1	11.1	11.1	11.1	11.1
	Max	Btu/h	367	735	1,103	1,471	1,839
	Min	x 1000	37	37	37	37	37
Heat Output at 50°C Flow - 30°C Return	Max	kW	119.7	239.4	359.1	478.8	598.5
	Min		12.2	12.2	12.2	12.2	12.2
	Max	Btu/h	408	816	1,225	1,633	2,042
	Min	x 1000	41	41	41	41	41
Nominal Heat Input Max	Nett	kW	114	228	342	456	570
		Btu/h	388,968	777,936	1,166,904	1,555,872	1,944,840
Input Rate NatGas Max		m <sup>3</sup> /h	12.06	24.12	36.18	48.24	60.3
		ft <sup>3</sup> /h	426	852	1278	1704	2130
Flow Temperature Max		°C	85	85	85	85	85
Max Operating Pressure		Bar	4.0	4.0	4.0	4.0	4.0
Min Operating Pressure		Bar	0.5	0.5	0.5	0.5	0.5
Flue Gas Volume Max Hot		m <sup>3</sup> /h	170	340	510	680	850
Combustion Air Volume Max		m <sup>3</sup> /h	130	260	390	520	650
Flue Gas Temperature Max		°C	80	80	80	80	80
Gas Inlet Pressure (NatGas) Min/Max		mbar	15/60	15/60	15/60	15/60	15/60
Flow & Return Connections	BSP-M		1 1/4"	1 1/4" (x2)	1 1/4" (x3)	1 1/4" (x4)	1 1/4" (x5)
Gas Connection	BSP-M		1"	1" (x2)	1" (x3)	1" (x4)	1" (x5)
Flue Connection		mm	110	110 (x2)	110 (x3)	110 (x4)	110 (x5)
Air Tube Connection (for room sealing)		mm	110	110 (x2)	110 (x3)	110 (x4)	110 (x5)
Weight	Empty	kg	155	310	465	620	775
	Full		170	340	510	680	850
Water Content		L	15	30	45	60	75
Electrical Supply 1 Phase			1 x 230V	2 x 230V	3 x 230V	4 x 230V	5 x 230V
Electrical Load Max		Watts	260	2 x 260	3 x 260	4 x 260	5 x 260
Condense Waste Connection	BSP-M		3/4"	3/4" (x2)	3/4" (x3)	3/4" (x4)	3/4" (x5)

## 3.2 critical dimensions

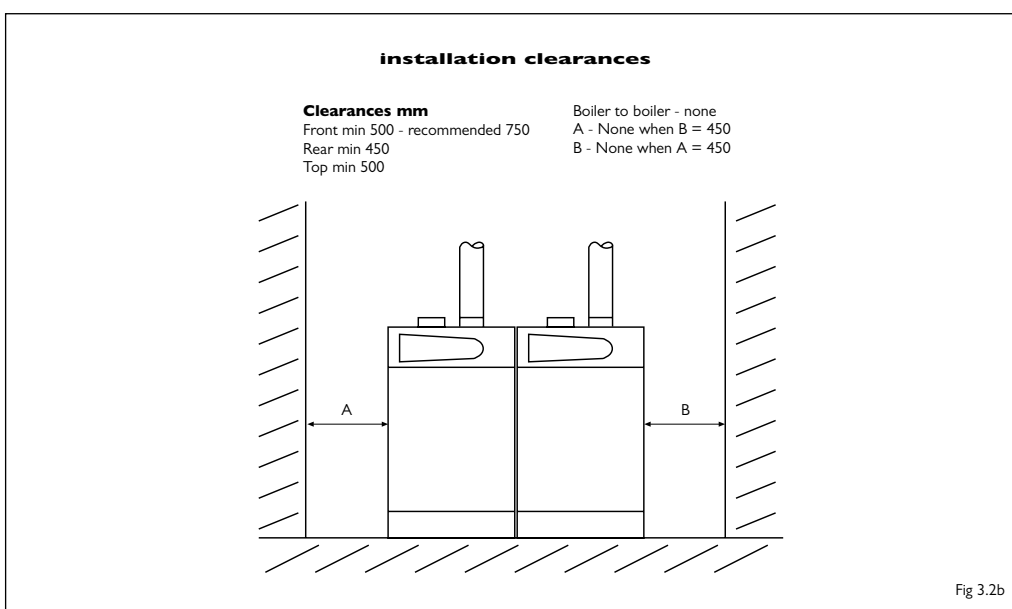
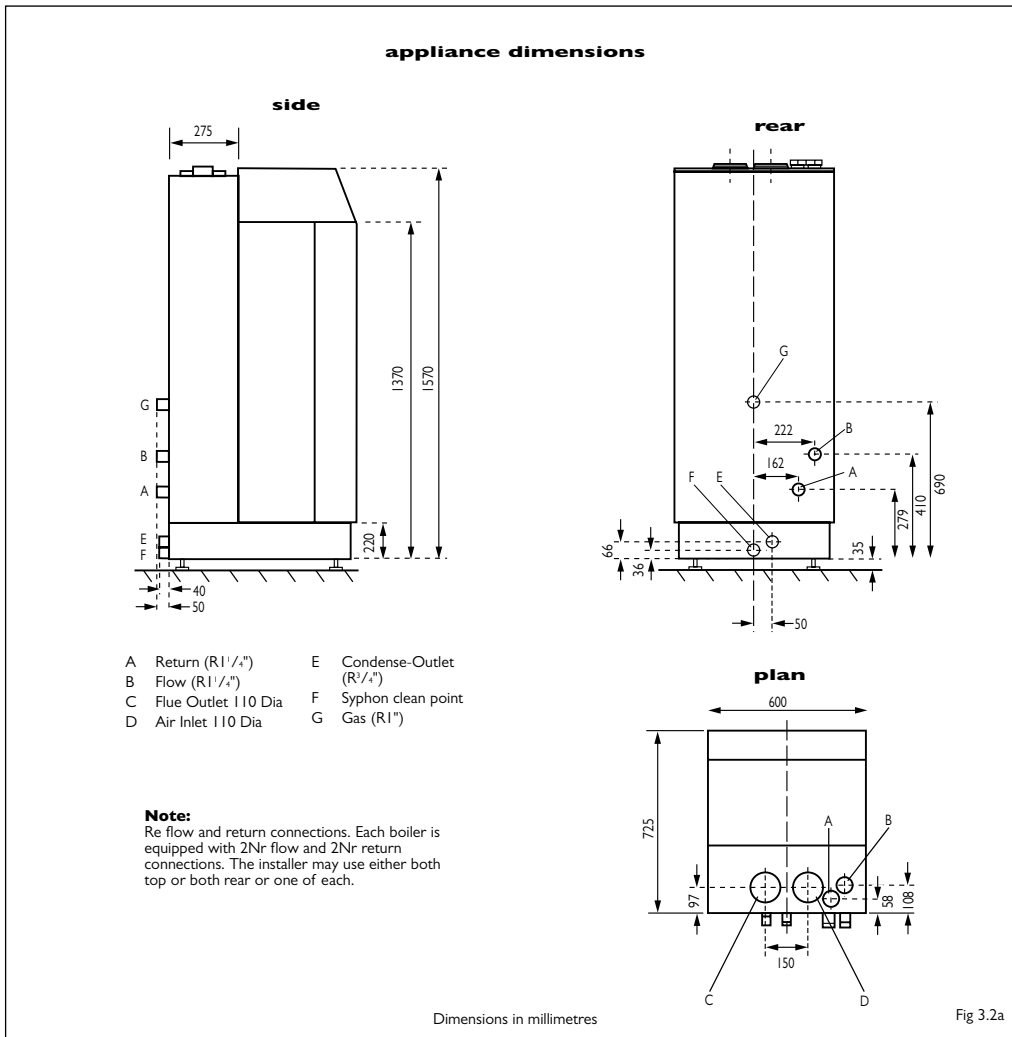

### 3.3 system guidance

In summary, the Strata is designed for use with a sealed pressurised hydronic circuit operating upon a design temperature difference of 20°C. The integral primary pumps have approximately 1m head available to overcome a primary loop incorporating a low velocity mixing header. Full details regarding suitable system designs are given in section 4.3.

### 3.4 flue options

The Strata 2-120 may be used with either an open or room sealed flue and air system. Approximately 100Pa is available as residual flue pressure at the exit from the appliance. Full details regarding flue specification are given in section 4.3.

## 4.0 appliance *installation requirements*

### 4.1 statutory requirements

#### **Gas Safety (Installation and Use) Regulations (Current Issue)**

It is the law that all gas appliances are installed by a registered person, in accordance with the above regulations. Failure to install appliances correctly could lead to prosecution. It is in your own interest, and that of safety, to ensure that the law is complied with.

In addition to the above regulations, this appliance must be installed in accordance with the current IEE Wiring Regulations for electrical installation, (BS 7671), Local Building Regulations, the Building Standards (Scotland) (Consolidation) Regulations, Bye laws of the Local Water Undertaking and Health and Safety Document No. 635 'The Electricity at Work Regulations 1989'.

It should also be in accordance with the relevant recommendations in the current editions of the following British Standards and Codes of Practice, plus any others that are relevant to the proposed installation: BS5449, BS5546, BS5440:1, BS6798, BS6891, BS6644, BS6880, IGE/UP/2, IGE/UP/7, & IM11. Clean Air Act Memorandum on Chimney Heights.

**Important Note:** Manufacturer's instructions must NOT be taken in any way as overriding statutory obligations.

### 4.2 boiler position

The following considerations must be observed when siting the Strata 2-120:

The boiler is not suitable for external installation. The position selected for installation should be within the building, unless otherwise protected by a suitable enclosure, and MUST allow adequate space for installation, servicing, and operation of the appliance, and for air circulation around it. (Refer to figure 4.3e). In a multiple set-up (modular set-up), the sides of the units may be placed against one another, without any room in between.

This position MUST allow for a suitable flue system and terminal position (Refer to sections 4.3). A connection to a suitable termination point for the discharge of condense must be available. If this is not present, a condensation pump with an elevation level of 5 metres may be fitted to the appliance. The Strata 2-120 must be installed on a flat horizontal floor which is capable of supporting the boiler and any ancillaries (circa 200kg).

If the appliance is to be fitted in a timber framed building it should be fitted in accordance with the British Gas publication 'Guide for Gas Installations In Timber Frame Housing', Reference DM2. If in doubt, advice must be sought from the Gas Supplier.

If the appliance is to be installed in a room containing a bath or a shower, any electrical switch or control utilising mains electricity must be so situated that it cannot be touched by a person using the bath or shower. Attention is drawn to the requirements of BS7671 (the current I.E.E. Wiring Regulations), and in Scotland the electrical provisions of the Building Regulations applicable in Scotland.

A compartment used to enclose the appliance MUST be designed and constructed specifically for this purpose. An existing cupboard, or compartment, may be used provided it is modified accordingly. BS 5376:2 gives details of the essential features of cupboard/compartment design, including airing cupboards.

## 4.2 boiler position (contd)

Where installation will be in an unusual location, special procedures may be necessary. BS6798 gives detailed guidance on this aspect.

The unit cannot be used in the vicinity of chlorine, halogen or sulphur as may be the case in environments such as swimming pools, coolant filling stations etc. In such cases the appliances MUST be room sealed to take air for combustion from outside of the building.

## 4.3 flue options & terminal position

The Strata 2 has an excess pressure combustion system that allows the appliance to be exhausted over extended distances using small OD flue components.

The flue gas temperature is extremely low (typically the same as the flow water temperature), which allows the use of easy to install PPS (polypropylene) flue pipe and fittings.

The appliance can take combustion air from the room in which it is installed (conventional application) or can be room sealed (fanned balanced flue) using a concentric flue arrangement of a 100mm PPS flue duct within a 150mm galvanised metal air duct, finished in off-white RAL 7035. A full range of flue pipe and air duct components including roof and wall terminals is available from MHS Boilers.

### list of flue components

- DN100 PPS tube x 1000mm
- DN100 PPS bend x 90°
- DN100 PPS bend x 45°
- DN100 wall bracket
- DN125 PPS tube x 1000mm
- DN125 PPS bend x 90°
- DN125 PPS bend x 45°
- DN125 wall bracket
- DN150 PPS tube x 1000mm
- DN150 PPS bend x 90°
- DN150 PPS bend x 45°
- DN150 PPS tee with 45° branch
- DN100 x 125 PPS increaser
- DN125 x 150 PPS increaser
- DN150 wall bracket
- 100/100 to 100/150 concentric adaptor
- 100/150 concentric tube x 1000mm
- 100/150 concentric bend x 90°
- 100/150 concentric bend x 45°
- 100/150 concentric horizontal terminal effective length 975mm
- 100/150 concentric vertical terminal effective length 500mm
- DN100 flat roof flashing
- DN100 pitched roof flashing
- DN125 flat roof flashing
- DN125 pitched roof flashing
- DN150 flat roof flashing
- DN150 pitched roof flashing
- Flat roof for 100/150 concentric terminal
- Adjustable pitched roof flashing for 100/150 concentric terminal

### calculating flue resistance

The excess pressure available for overcoming the frictional resistance of a flue system is 100 P.a. The table of flue component resistances will assist the designer in calculating total flue system frictional loss.

If the total installed flue system resistance exceeds 100 P.a., then the result will be a reduction in boiler output. Reference to the "Effect of Flue System Resistance On Boiler Output", graphs will assist. If the resistance of a proposed flue system has an unacceptable effect on boiler output, then a larger diameter flue tube should be selected. Thermal up-draught is generated in a vertical flue system, reducing the resistance of the system. Reference to the "Thermal Up-draught Graph" will provide a figure in P.a., which may be deducted from the total calculated flue system resistance.

**Note:** Does not apply to horizontal sections of a flue system.

## 4.3 flue options & terminal position (contd)

**Table 3**

PPS Component Resistance Pa	For Single Boiler
1m Length DN100 Flue Gas tube	7.0
1m Length DN100 Tube Carrying Air	4.0
90° Bend DN100 Carrying Flue Gas	7.0
90° Bend DN100 Carrying Air	4.0
45° Bend DN100 Carrying Flue Gas	4.0
45° Bend DN100 Carrying Air	2.0
1m Length 100/150 Concentric Tube	12.0
90° 100/150 Concentric Bend	12.0
45° 100/150 Concentric Bend	6.0
100/150 Concentric Terminal Vertical or Horizontal	15.0
100/100 to 100/150 Concentric Adaptor	2.0
DN100 Open Termination with Bird Mesh	7.0
DN100 Air Tube Termination with Rain Cap	8.0
DN125 Air Tube Termination with Rain Cap	5.0

PPS Component Resistance Pa	For Single Boiler
DN150 Air Tube Termination with Rain Cap	2.0
1m Length DN125 Flue Gas tube	2.5
1m Length DN125 Tube Carrying Air	1.5
90° Bend DN125 Carrying Flue Gas	2.5
90° Bend DN125 Carrying Air	1.5
45° Bend DN125 Carrying Flue Gas	1.5
45° Bend DN125 Carrying Air	1.0
DN125 Open Termination with Bird Mesh	2.5
DN150 Open Termination with Bird Mesh	1.0
1m Length DN150 Flue Gas tube	1.0
1m Length DN150 Tube Carrying Air	0.5
90° Bend DN150 Carrying Flue Gas	1.0
90° Bend DN150 Carrying Air	0.5
45° Bend DN150 Carrying Flue Gas	0.5
45° Bend DN150 Carrying Air	0.5

### examples of calculating flue pressure loss

**example 1**

A single Strata 2-120 boiler is to be installed with a conventional flue arrangement (taking combustion air from the plantroom) which takes an all vertical internal route to roof termination using DN100 flue components.

Length of flue = 10m

Resistance =

10 x 1m lengths DN100 tube @ 7.0Pa = 70

1 x DN100 open termination @ 7.0Pa = 7

Total Resistance = 77Pa

Take into account that 10m of internal vertical flue will generate approximately 33Pa of draught then final operating resistance is 77 - 33 = 44Pa

**conclusion:** Operating resistance is less than 100Pa therefore no alternative design is required as flue system has no effect on boiler output.

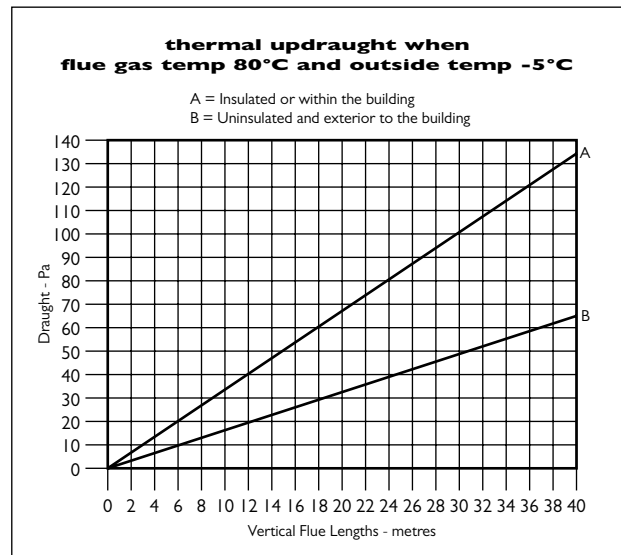

## examples of calculating flue pressure loss

### example 2

A single Strata 2-120 boiler is to be installed with a room sealed flue using separate air and flue gas tubes of DN100.

The flue gas tube takes a part horizontal, part vertical internal route to a roof termination. The air tube takes a similar route. Flue gas route vertical section = 3m, horizontal section = 2m. System includes 2 x 90° bends.

Resistance of flue gas tube =  
 5 x 1m lengths DN100 tube @ 7.0Pa = 35  
 2 x DN100 90° bends @ 7.0Pa = 14  
 1 x open termination @ 7.0Pa = 7

Flue gas tube resistance = 56Pa.

Take into account 3m of vertical tube will generate 10Pa. Therefore operating resistance of flue gas tube = 56 - 10 = 46Pa.

Now calculate air tube resistance which must be added to flue gas tube operating resistance to obtain final resistance.

Air tube length = 6.5m (no consideration is given to whether vertical or horizontal). System includes 2 x 90° bends.

Resistance of air tube =  
 6.5 x 1m lengths DN100 tube @ 4.0Pa = 26  
 2 x DN100 90° bends @ 4.0Pa = 8  
 1 x DN100 termination with rain cap @ 8.0Pa = 8

Air tube resistance = 42

Total operating resistance = 56 + 42 = 98Pa

**conclusion:** Final operating resistance is less than 100Pa, therefore no alternative design is required as flue system has no effect on boiler output.

### example 3

A single Strata 2-120 is to be installed using 100/150 concentric flue components. The flue route is all horizontal, to a horizontal wall termination

Length of flue = 4m

System includes 1 x 90° bend + 2 x 45° bends.

Resistance =  
 4 x 1m lengths 100/150 concentric tube @ 12Pa = 48  
 1 x 100/150 90° concentric bends @ 12Pa = 12  
 2 x 100/150 45° concentric bends @ 6Pa = 12  
 1 x 100/100 to 100/150 concentric adaptor @ 2Pa = 2  
 1 x 100/150 concentric terminal @ 15Pa = 15

Total resistance = 89Pa.

**conclusion:** Total flue system resistance is less than 100Pa, therefore no alternative design is required as flue system has no effect on boiler output.

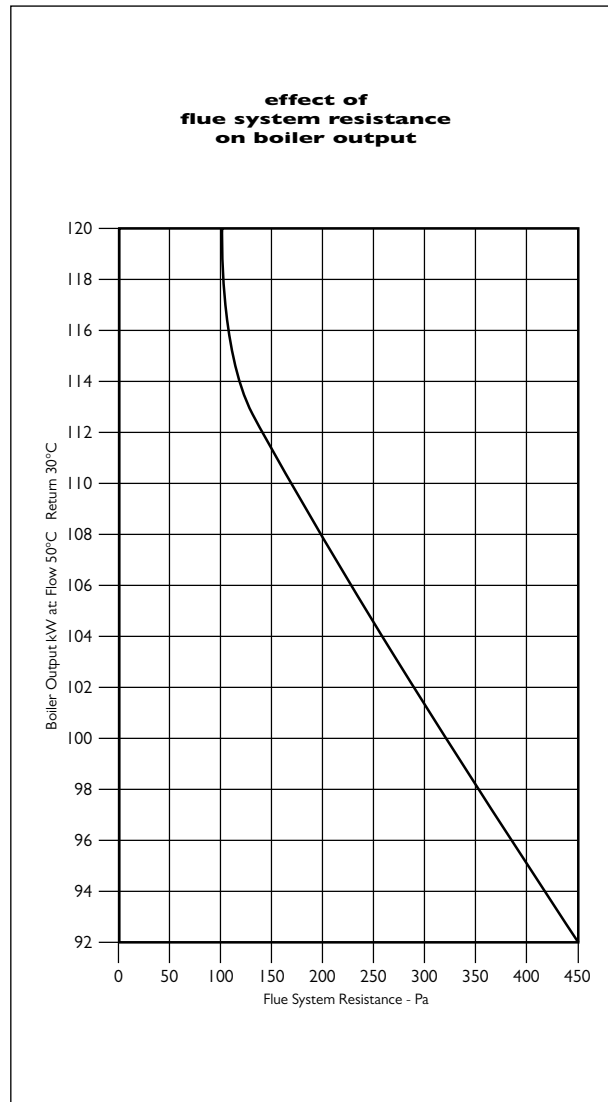

## 4.3 flue options & terminal position (contd)

### multiple flue system calculation

For flue component resistance for multiple boiler installations refer to graph below.

Volume flue gas per boiler = 170m<sup>3</sup>/h

Volume combustion air per boiler = 130<sup>3</sup>/h

Assume resistance of 45° bend = 0.5 tube

Assume resistance of 90° bend or tee = 1.0m tube

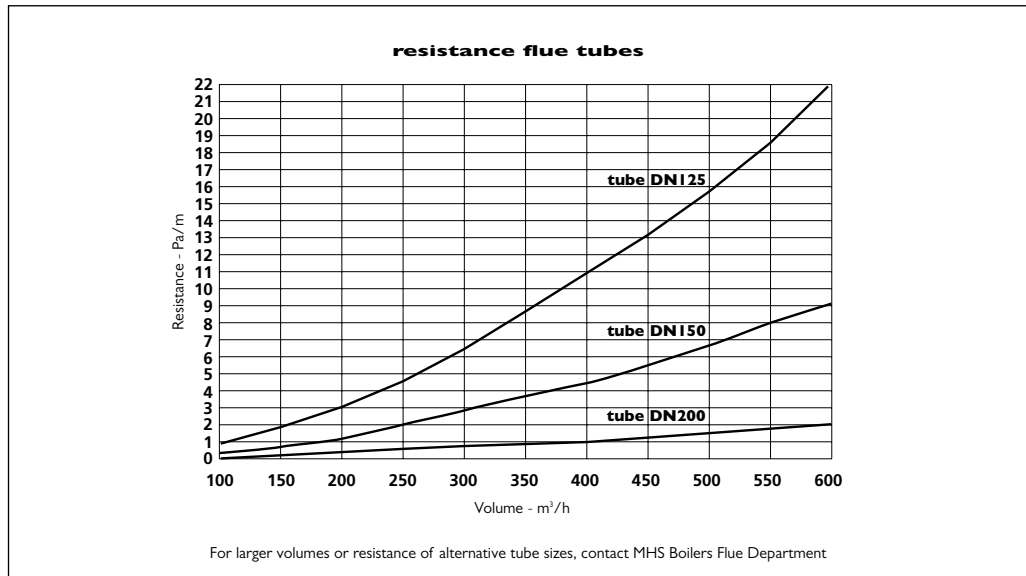

### flue system layouts

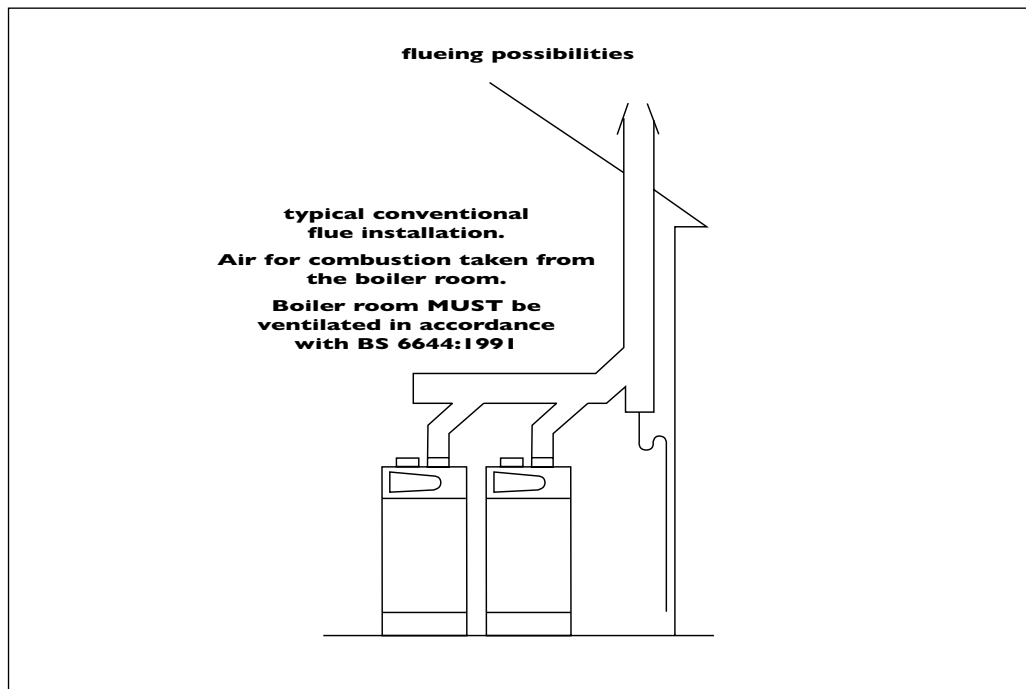

## 4.3 flue options & terminal position (contd)

### flue system layouts

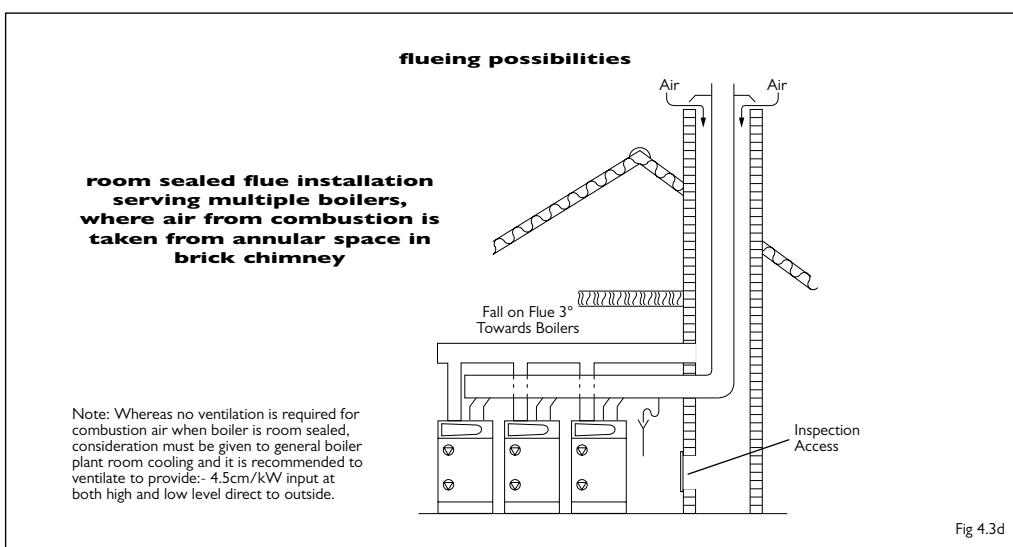
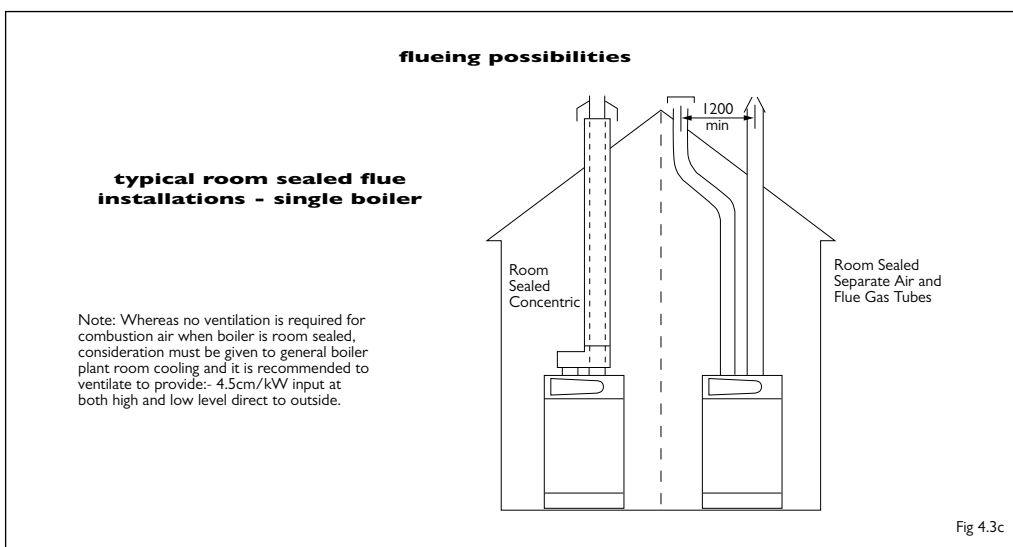
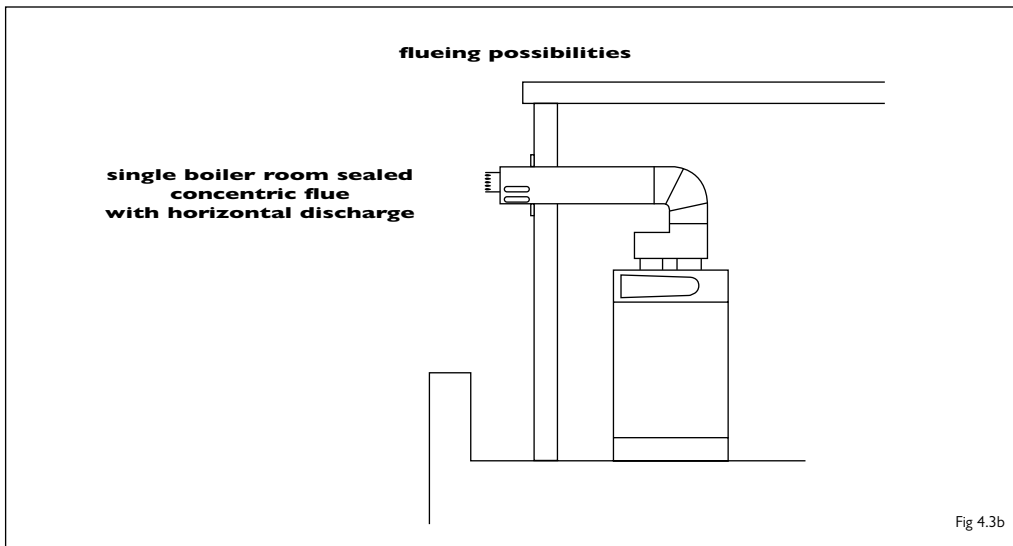

## 4.3 flue options & terminal position (contd)

### Additional Notes for Room Sealed Appliances:

The Clean Air Act Memorandum prevents the use of balanced flue appliances discharging at low level where the total heat input to the plant room exceeds 150kW. Where the Clean Air Act does not prevent installation, the following rules must be applied.

**Note:** Detailed recommendations for flue installation are given in BS5440:1

The following points are for general guidance:

- The boiler must be installed so that the terminal is exposed to external air.
- It is important that the position of the terminal allows free passage of air across it at all times.
- It is essential to ensure that products of combustion discharging from the terminal cannot re-enter the building or any other adjacent buildings, through ventilators, windows, doors, other sources of natural air infiltration, or forced ventilation/air conditioning.
- The minimum acceptable dimensions from the terminal to obstructions and ventilation openings are specified in figure 4.3e.
- If the terminal discharges into a pathway or passageway check that combustion products will not cause nuisance and that the terminal will not obstruct the passageway.
- Where the lowest part of the terminal is fitted less than 2m (78ins) above ground, above a balcony or above a flat roof to which people have access, the terminal **MUST** be protected by a purpose designed guard.
- Where the terminal is fitted within 850mm (34ins) of a plastic or painted gutter, or 450mm (18ins) of painted eaves, an aluminium shield at least 750mm long must be fitted to the underside of the painted surface.
- The air inlet/flue outlet duct **MUST NOT** be closer than 25mm (1 in) to combustible material.

**Note:** Under most weather conditions the terminal will emit a plume of steam. This is normal but positions where this would cause a nuisance should be avoided.

In the case of horizontal flue gas discharge pipes, an angle of 3° must be observed in the direction of the boiler (5.0cm for every metre of pipe length) with a fall towards the boiler, to allow condense in the flue gases to return to the unit.

Minimum dimensions of flue terminal positions:

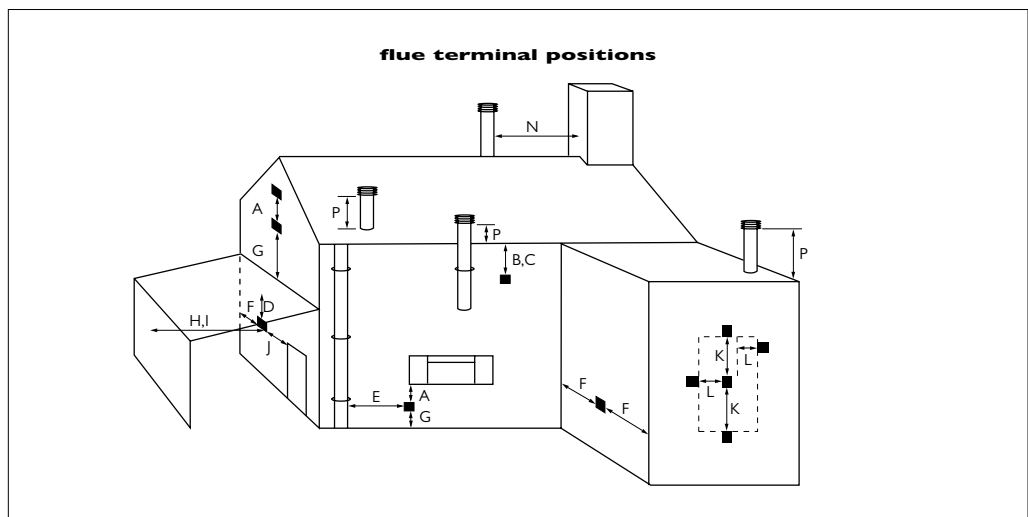

### 4.3 flue options & terminal position (contd)

**Table 4**

Dimension	Terminal Position	Balanced Flue Room Sealed	Non room Sealed
A	Directly below an opening, air brick, window etc	300mm Not recommended	300mm Not recommended
B	Below gutters, soil pipes or drain pipes	75mm	75mm
C	Below eaves	200mm	200mm
D	Below balconies or carport roof	200mm Not recommended	200mm Not recommended
E	From a vertical drain pipe or soil pipe	75mm	75mm
F	From an internal or external corner	300mm	200mm
G	Above ground, intersecting roof or balcony level	300mm	300mm
H	From a surface facing the terminal	2000mm	2000mm
I	From a terminal facing the terminal	2000mm	2000mm
J	From an opening in the carport e.g. door into dwelling	1200mm Not recommended	1200mm Not recommended
K	Vertically from a terminal on the same wall	1500mm	1500mm
L	Horizontally from a terminal on the same wall	300mm	300mm
M	From the wall on which the terminal is mounted	N/A	50mm
N	From a vertical structure on the roof	500mm	N/A
P	Above intersection with roof	500mm	150mm

### 4.4 ventilation requirements

Detailed recommendations for air supply are given in BS 6644:1991. The following notes are for general guidance. If the combustion air is to be taken from the room in which the unit is located, a guard must be placed over the air intake to prevent the entry of any foreign bodies.

#### Room Sealed Installations Only:

If the boiler is to be installed in a cupboard or compartment, permanent air vents may be required for cooling purposes in the cupboard or compartment. It is essential to ensure that the minimum clearances as stated in figure 3.2b are maintained.

Water must not be allowed to enter the air intake, as this may affect the performance and behaviour of the combustion fans.

# STRATA 2

## 4.5 hydraulic system design

**Important Note:** Strata 2 boilers must only be installed on sealed and pressurised systems. A sealed system must only be filled by a competent person. Instructions for filling the system are supplied in section 6.0. A low pressure cut off switch must be installed into the system.

**All systems must be thoroughly cleansed prior to the connection of the boiler. The system water should be treated to prevent general system corrosion and the deposition of scale or sludge in the boiler waterways. Failure to observe this requirement will render all guarantees on the product void.** If installing the boiler onto an old system, it is recommended to install a spirotech or similar dirt arrester/filter.

If plastic pipes are used for the flow and return lines, for radiators or underfloor heating, a plate exchanger should be considered between the system water and the boiler water. If such a separator is not used, the MHS guarantee on all boiler parts will become null and void, unless it can be proved that the plastic pipes used have a vapour tight layer.

The connection of the flow and return are located at the top and the rear of the unit. With regards to servicing, it is a requirement that isolation valves are installed.

For specialist advice and water treatment products, contact:

Betz Dearborn  
Widnes, Cheshire WA8 8UD  
Tel: 0151 424 5351

Fernox, Britannica Works  
Clavering, Essex CB11 4QZ  
Tel: 01799 550811

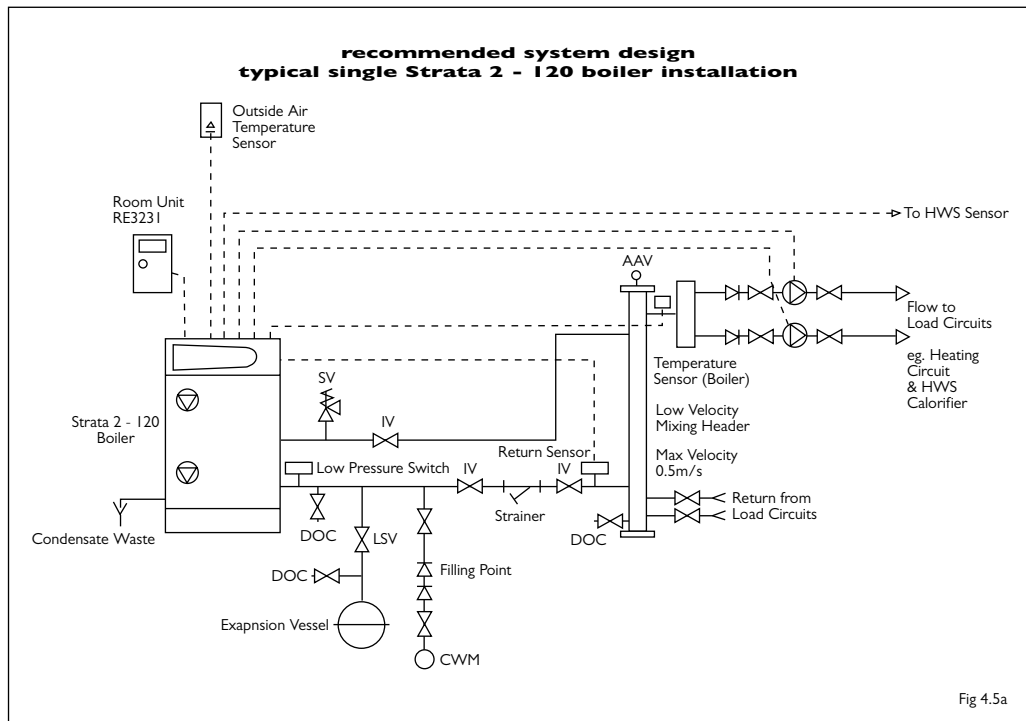

## 4.5 hydraulic system design (contd)

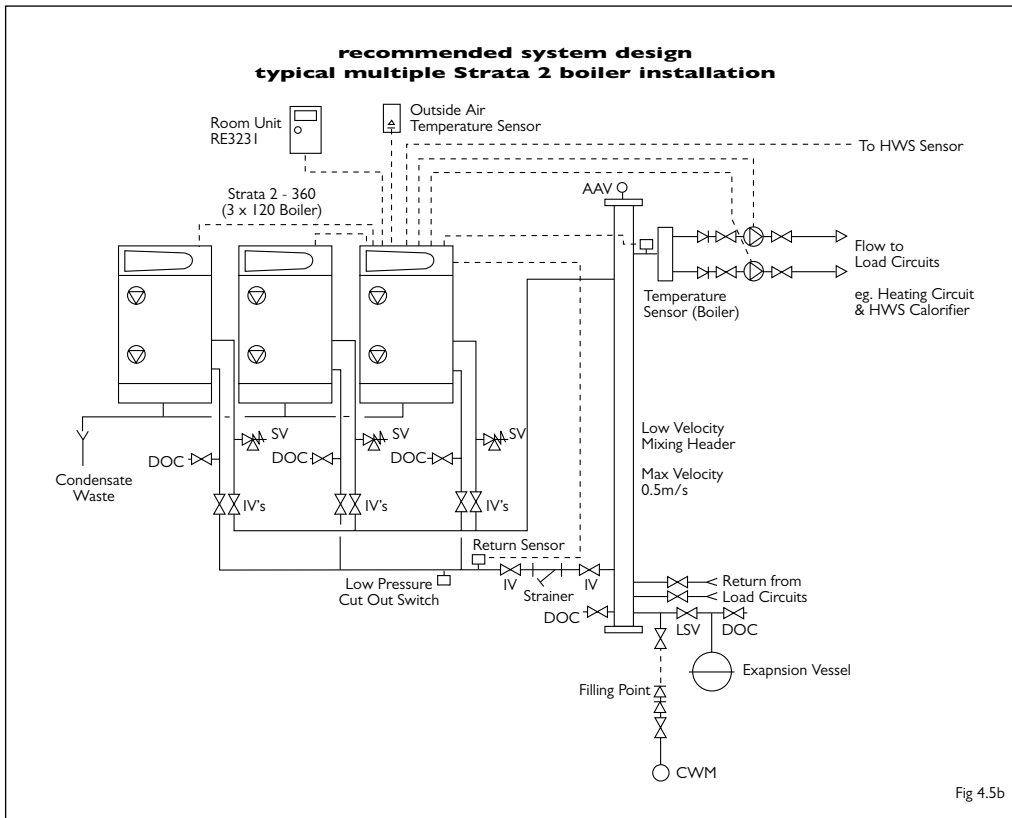

## 4.6 gas supply

The Strata 2-120 is designed and set for Natural Gas group G20. The Gas Supplier should be consulted at the installation planning stage in order to establish the availability of an adequate supply of gas.

An existing service pipe **MUST NOT** be used without prior consultation with the gas supplier. A gas meter can only be connected by the gas supplier or by their contractor.

An existing meter and/or pipework should be of sufficient size to carry the maximum boiler input plus the demand of any other installed appliance. (BS 6891:1988). A minimum of 1" BSP diameter pipework is required to within 1 metre of the appliance gas cock.

The governor at the meter must give a constant outlet pressure of 20 mbar (8 in. wg) when the appliance is running.

The gas supply should be purged in accordance with IGE/UP/I&2. **WARNING:** Before purging open all doors and windows, also extinguish any cigarettes, pipes and any other naked lights.

## 4.7 electrical supply

A 240 Volt single phase supply must be present at the proposed boiler location. Wiring external to the appliance must be in accordance with BS7671 (the current I.E.E. Wiring Regulations) for electrical installation and any local regulations which apply.

The mains cable must be at least 0.75mm<sup>2</sup> (24/0.2mm) PVC insulated to BS6500 table I6. The method of connection to the mains supply must facilitate complete electrical isolation of the appliance. Either a 5A fused three pin plug and un-switched shuttered socket outlet, both complying with BS1363, or a 5A fused double pole switch having a 3mm contact separation in both poles and serving only the boiler (and its external controls) may be used.

### **WARNING: THIS APPLIANCE MUST BE EARTHED.**

(Failure to provide a satisfactory Earth connection would be a safety hazard and may also result in appliance malfunction).

## 5.0 installation *instructions*

### 5.1 unpacking the boiler

The boiler is delivered in a palletted carton containing the boiler and associated fittings, plus any other optional ancillary flue or control components in separate cartons.

The boiler carton contains:

- Fully assembled boiler.

The Strata 2-120 is also delivered with the following items:

- User manual and operating instructions.
- Installation and Servicing instructions for the Engineer.

Built into each unit are the following:

- A gas stop cock for each heat module.
- Three way return water cut-off.
- RVA 47 control unit (master and slave boilers), 1 outside air sensor, 1 flow sensor and 1 return sensor.

The unit must be inspected immediately after delivery. Any damage to the consignments must be reported within 3 days.

To unpack the boiler, carefully cut away the outer packaging and open the carton top. Lift off the bottomless carton. By holding the chassis only lift the appliance away from the palette.

To remove the casing from the boiler:

- Remove the two screws on the bottom front edge of the top casing panel.
- Remove panel to the front.

### 5.2 positioning the boiler

Move the appliance to the desired location, making sure that all clearance dimensions as stated in section 3.2 are adhered to. Level the appliance in a vertical position by turning the adjustable feet underneath the base of the unit. Check that the appliance is in a true vertical position by using a spirit level. Once the appliance is in a true vertical position, the adjustable feet must be secured by locking the nuts.

### 5.3 air supply and exhaust connections

The unit has two connections, one for the supply of combustion air and the other for the discharge of the products of combustion. Each connection is clearly labelled and located at the rear top of the appliance.

### 5.4 gas connection

The Gas connection is located at the rear of the appliance. The gas supply should be sized, installed, tested and purged in accordance with IGE/UP/I&2.

The connection to the appliance must include a suitable method of disconnection and a gas control cock must be installed adjacent to the appliance for isolation purposes.

The gas pipe used to supply the appliance must not allow a pressure drop of greater than 1 mbar from the meter to the appliance. The nominal inlet working gas pressure measured at the appliance should be 20.0 mbar for Nat Gas (G20). The installer should install a pressure test point adjacent to the gas inlet connection. The gas supply line should be purged.

**WARNING:** Before purging open all doors and windows, also extinguish any cigarettes, pipes and any other naked lights.

## 5.5 Water Connections

The central heating flow and return connections are 1 1/4" BSP male. Two sets of flow and return connections are provided and located on the rear top of the appliance and the rear of the appliance. The installer may use both top or both rear connections or one of each for connection of the flow and return pipes.

A suitable safety valve must be installed onto the boiler flow pipe between the boiler and any isolation valve. The boiler flow and return pipes must include a method of disconnection and must include isolation valves.

## 5.6 condense waste connections

The condense waste connection is located at the lower rear of the appliance. The condense syphon cleaning point is factory fitted with a heavy grade black plastic cap which **MUST NOT BE REMOVED**. Operating the appliance with the cap removed from the syphon cleaning point will allow products of combustion to be discharged from the cleaning point.

The condense waste connection is a 3/4" BSP male threaded stub fabricated from plastic. The installer must connect to this stub, a condense waste pipe fabricated from plastic tube and fittings (3/4", 22mm overflow pipe is considered suitable). Only plastic components must be used for the condensation discharge. Metal pipes are not acceptable due to the acidic nature of the condensate.

The built in syphon allows the unit to be connected directly to a drain system. If any part of the condense waste pipe is to be run external to the building or is at risk of freezing, then the pipe must be suitable insulated to protect from freezing.

If a suitable drain for accepting the condense waste is not available nearby to and below the boiler (e.g. if the boiler is installed in a basement below ground level), then an (optional extra) condensate receptacle and pump can be installed into the free space at the base of the appliance. This will collect and remove condense water to a remote drain up to 5 metres height difference above the receptacle position.

**Note:** Blockage of the waste discharge will cause the unit to switch off by means of a built in level switch.

When making the condense waste pipe connection to the boiler, do not use adhesives, it is recommended to lightly apply a suitable jointing tape (PTFE or similar) and use only light pressure to connect fittings to the appliance to avoid damage to the condense waste outlet assembly. It is recommended that the condense waste pipework should include a method of disconnection and cleaning points.

## 5.7 electrical connections – general

The Strata 2-120 has a number of standard connection points. In addition, a number of panel locations have been reserved for the installation controller, which can be mounted in the spaces provided after removing the blank panels.

At the top of the boiler, behind the controllers, is a connector plate stretching across the entire width of the boiler, flanked by three cable clamp brackets. All electrical connections are made via plugs and sockets and to avoid mistakes during the connection of the cables, each plug has its own colour.

### 5.7.1 connecting the power supply

The incoming power supply (230V) must be connected to the black 3 pin Weiland plug located at the far left hand side of the connectors mounting plate in the top area of the boiler. The unit has a 2-pole on/off switch for the power supply of the entire boiler and all the connected controllers, pumps and valves.

Determine the cross sectional area of the power supply cable and take into account the power usage of the combined components connected to the control units.

In addition each burner module has a single pole-switch to switch off one burner unit while the second unit may continue to function. The main switch is protected by a 6.3 AT fuse.

**CAUTION:** The main power supply for the boiler must have a higher fuse value.

## 5.7.2 connecting of system safety interlocks

These switches are connected to the 'dark green' 3 pole plug. The central pole provides the common output (230V AC). The left hand terminal enables the lower module and the right hand terminal enables the upper module.

## 5.7.3 connecting remote run indication lamps

Connection points have been provided for the connection of run indication lamps (20W max). See "Electrical Connection Details" fig 5.7a, for terminal positions.

**CAUTION:** These outputs must not be linked together as this will result in false lockout being experienced by the burner control panels.

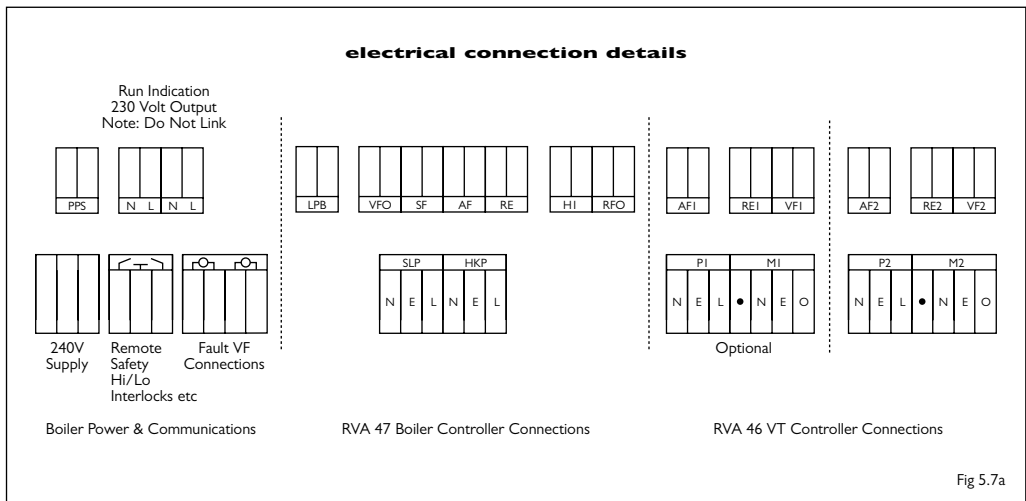

### Legend

- PPS. Connection for the Master boiler to a second boiler - **Note screened cable must be used.**
- LPB. Connection for the Master RVA 47 controller to subsequent RVA 47 controllers - **Note screened cable must be used.**
- VFO. Connection for the system flow sensor.
- SF. Connection for the DHW sensor.
- AF. Connection for the outside air sensor.
- RE. Connection for the room unit.
- HI. Connection for remote enabling volt free or 0-10 Volt control signal.
- RFO. Connection for the system return sensor.
- SLP. Connection for the DHW 3 way valve or charging pump. (Max 2A).
- HKP. Connection for the Heating pump. (Max 2A).
- AF1/AF2. Connection for another outside air sensor dedicated for the RVA 46 if required. If a dedicated sensor is not required the RVA 46 will use the RVA 47 outside air sensor.
- RE1/RE2. Connection for the room unit/thermostat dedicated to the RVA 46 VT circuits
- VF1/VF2. Connection for the mixed flow sensor of the RVA 46 VT circuits
- P1/P2. Connection for the pump of the RVA 46 VT circuits.
- M1/M2. Connection for the 3 way mixing valve of the RVA 46 VT circuits.

## 5.7.3 connection diagrams

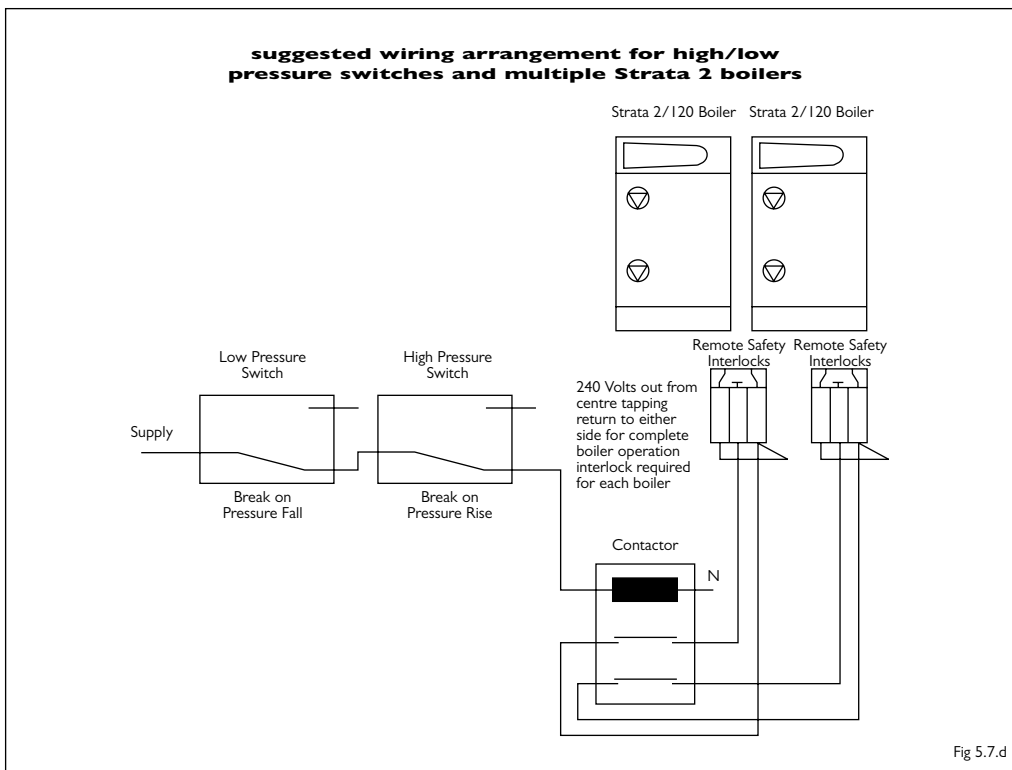
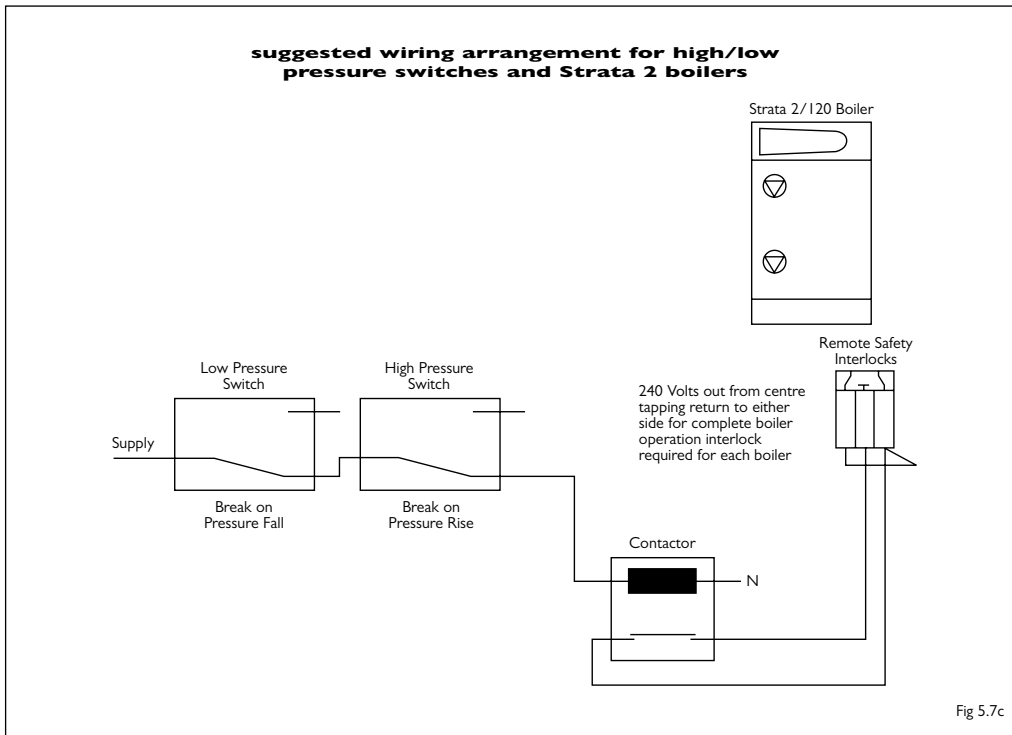

## 5.7.3 connection diagrams

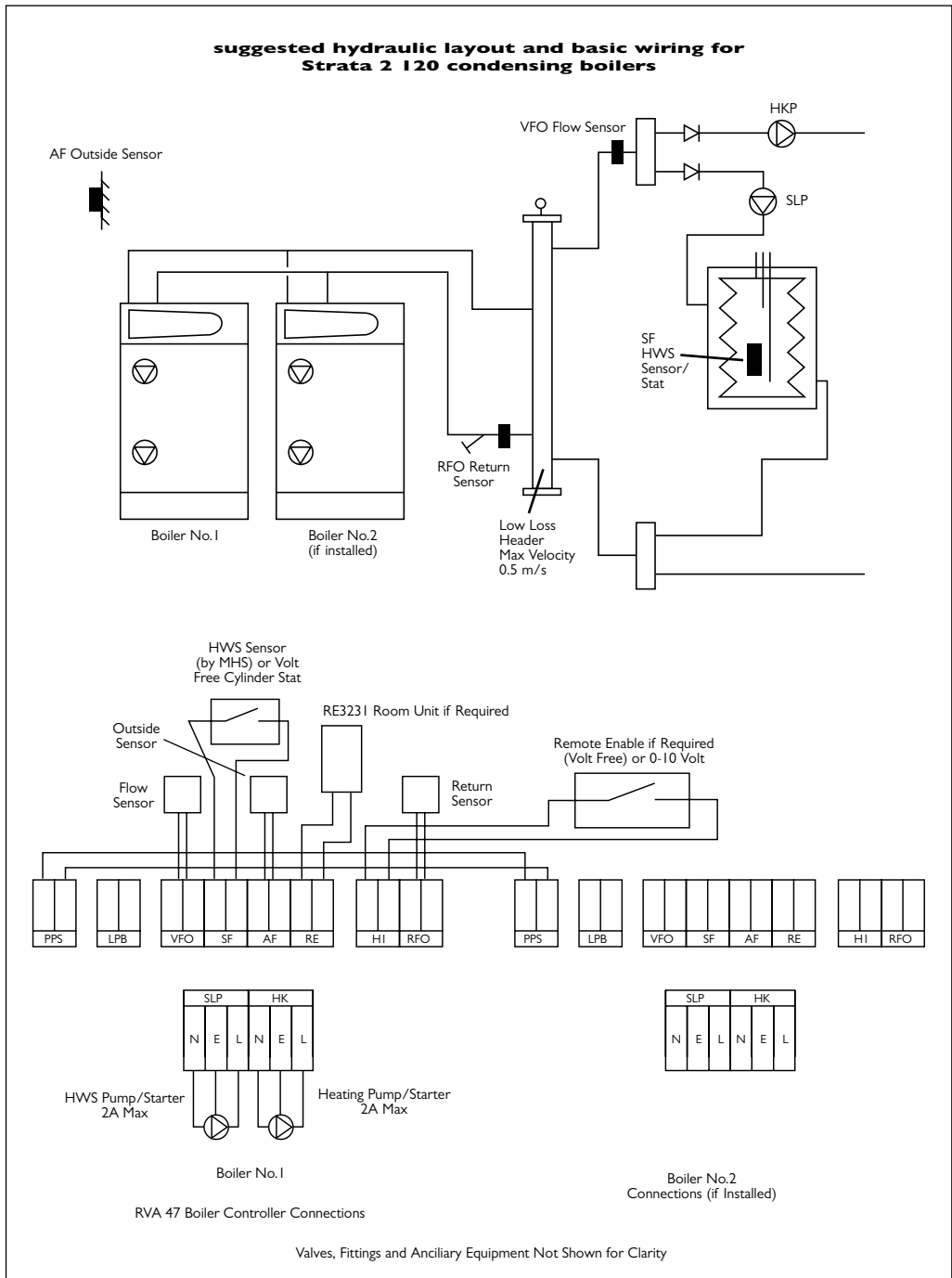

## 5.7.3 connection diagrams

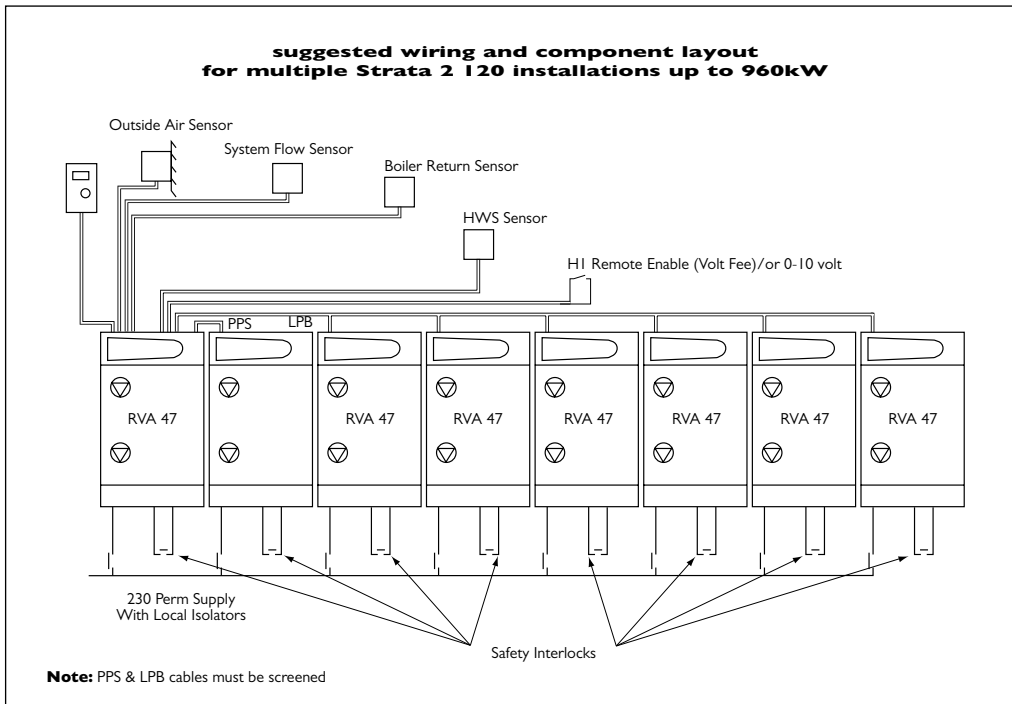

## 5.7.4 electrical wiring diagram

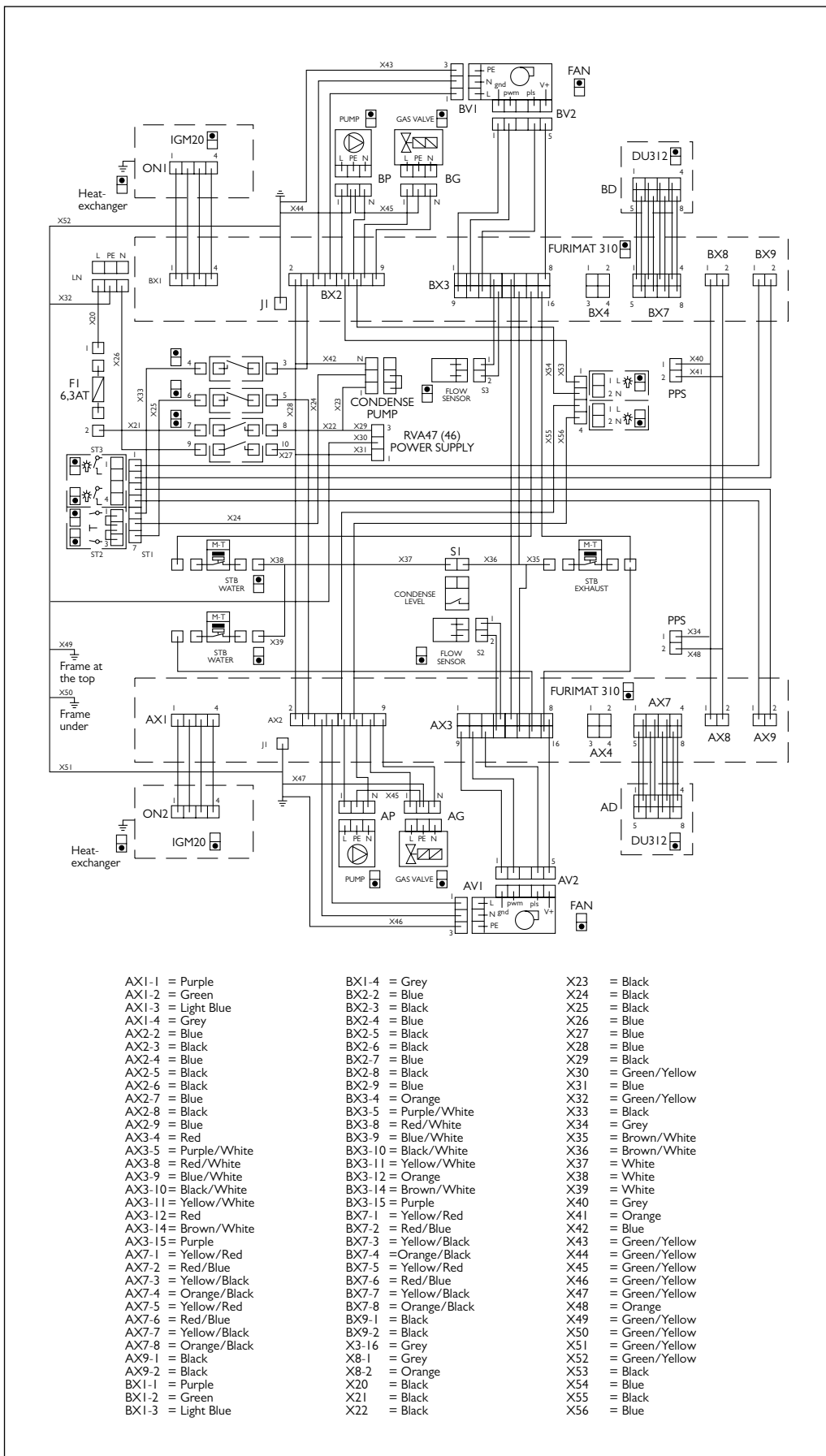

## 5.7.5 connecting remote fault alarms

The boiler includes a normally open volt free contact for each module, which closes in the event of a lockout failure. See “Electrical Connection Details” section 5.7.

## 5.8 connecting additional boilers

A second boiler unit does not require an additional RVA 47 manager, as the manager in the first unit is capable of controlling up to 4 burners. Connect the power supply to the second unit. Install a pair of screened wires between the PPS connectors of boilers 1 and 2. Observe polarity.

**Note:** PPS connector = light blue.

### 5.8.1 connecting third, fourth, fifth, sixth, seventh and eighth units

These boilers must have RVA 47 managers. To connect RVA 47 manager in additional boilers; the LPB terminals in each boiler that includes an RVA 47 manager must be linked, i.e. all left hand LPB terminals must be linked on to another, and all right hand LPB terminals must be linked one to another. Do not link any left hand terminal to any right hand terminal. Screened cables required.

### 5.8.2 boiler manager RVA 47 installation procedure (normally factory fitted)

Complete the following steps to install the manager:

- Remove the blank panel to the right of the display panel.
- Unpack the RVA 47 and insert it in the opening of the control panel.
- Place the first wiring harness with 6-pin connector in the bottom of the RVA 47 and click the other end into the wiring upstand at the rear of the boiler.
- Place the second wiring harness with the 8-pin connector in the top of the RVA 47 and click the other end into the wiring upstand at the rear of the boiler.
- Connect the boiler power supply (3 pin male connector) to the RVA 47 unit.
- Connect the PPS communication wire (Orange/Grey) to the female plug connected to the (Blue/Grey) wire.

The following can now be connected as necessary:

**Table 5**

SLP	DHW pump or 3-way valve	Beige
HKP	Heating system pump	Yellow
PPS	Connection to second boiler	Blue
LPB	Connection to subsequent RVA 47	Mauve
*VFO	Flow sensor	White
SF	DHW sensor	Clear
*AF	Outside air sensor or resistor substitute (620 Ω)	Black
REO	Room unit or thermostat	Light blue
HI	Remote enable or (volt free) 0-10 Volt	Orange
RFO	Return Sensor	Clear

\* = Compulsory connections. All other connections as necessary.

## 5.8.3 mixing valve controller RVA 46 installation procedure

Complete the following steps to install the RVA 46:

- Remove the blank panel beside the manager.
- Unpack the RVA 46 and insert it in the opening of the control panel.
- Place the wiring harness with 7-pin connector in the bottom of the RVA 46 and click the other end into the wiring upstand at the rear of the boiler.
- Place the wiring harness with the 6-pin connector in the top of the RVA 46 and click the other end into the wiring upstand at the rear of the boiler.
- Connect the controller power supply from RVA 47 loom.
- Connect LPB circuit (pink and mauve) from RVA 47 loom.

The following can now be connected if necessary:

**Table 6**

PI	Pump for mixed circuit	Brown
MI	Three way mixing valve	Brown
AFI	Outside air sensor	Black
REI	Room unit or thermostat	Light-blue
VFI	Mixed flow sensor	White

## 5.9 connecting a condensate pump

If a suitable drain for condensate disposal is located too high to be able to discharge the condensate water from the boiler, a condensate pump must be installed within the base of the boiler.

This condensate pump has a built-in safety device. If the pump outlet is blocked, the water level in the pump reservoir will rise to just below the rim – if the level rises any further, the power to the boiler will be switched off.

At the right hand side, in the area of the boiler base, there is a socket – if no condensate pump is used, there will be a plug with a control link in place. The condensate pump (KHPI) must be wired into this plug once the link wire has been removed.

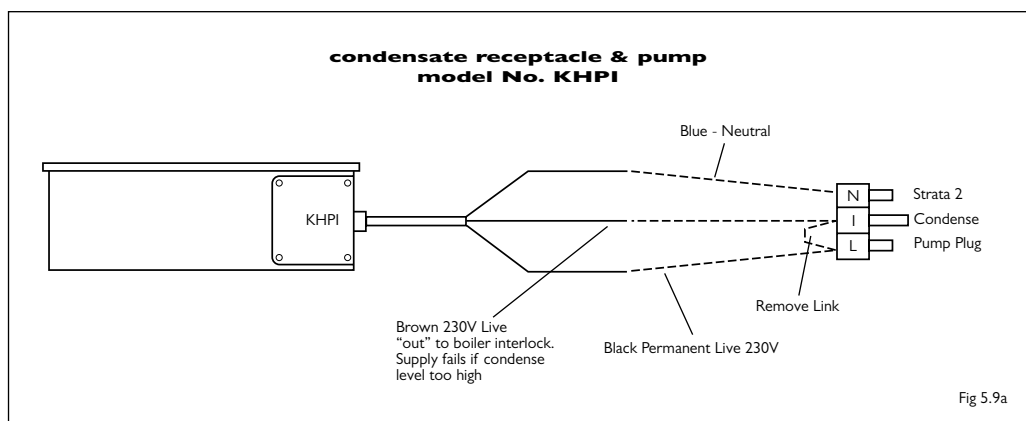

## 5.9.1 Condensate Receptacle and Pump – Model No. KHPI

The KHPI condensate pump is designed to collect and pump away condensate water produced by condensing boilers and is particularly suitable for use with the Strata 2.

The KHPI may be installed directly inside the base area of the Strata 2 making a concealed installation. The receptacle includes a permanently wet sump area where pH adjustment granules may be dosed to neutralise the pH of the condensate water.

### technical data

Pump Transfer Height	5m
Transfer Volume/cycle	2 litres (approx)
Transfer Time/cycle	17 seconds (approx)
Power Supply	230V 50Hz
Pump	12V dc
Pump Outlet	10mm OD Male Spigot
Capacity pH Granules	7kg
Dimensions	465W x 380D x 120H
Supply Cable Length	1.8m
10mm Discharge Hose Length	5m
Condense Inlet	open aperture in unit top

## 6.0 commissioning *and testing*

The Strata 2-120 should be commissioned by a competent engineer. Before commissioning the appliance, the whole gas installation including the meter MUST be purged and tested for gas soundness in accordance with BS6891:1988.

**CAUTION:** Open all doors and windows, extinguish naked lights and DO NOT SMOKE whilst purging the gas line.

The entire system must be thoroughly cleansed and flushed to remove debris, flux residues etc before opening the boiler isolation valves and flooding the boiler. Particular care must be taken where the appliance is being retro-fitted into an old/existing system, as system silt or magenite can be very damaging to the new boiler.

**Following cleansing and flushing the system must be dosed with a good quality water treatment to prevent corrosion and the formation of scale. Failure to observe these requirements will render the guarantee on the product void.**

**Cleansing, flushing and water treatment must be carried out in accordance with the requirements of BS7593:1992.**

The return pipework must include some method of filtering or straining. The filter or strainer must be fitted with isolation valves to allow easy cleaning with the minimum amount of water loss and water replenishment.

A low water pressure switch must be included within the system design and interlocked to the boiler to shut the boiler down in the event of the water pressure falling below 0.5 bar.

**Note: The Strata 2 boiler has heat exchangers fabricated from 316L stainless steel. It is most important that the compatibility of any flux is checked with the flux supplier before use, and that any flux manufacturers recommendations are strictly followed with regards to use in conjunction with stainless steel.**

### 6.1 Filling the Boiler

The Strata 2-120 and the central heating installation must be filled by a competent person using one of the approved methods in BS 6644:1991 and using the filling/draining cock in the installation.

The unit has a manometer, which indicates the filling pressure. Fill the installation and vent the boiler. Continue to fill the installation until the correct central heating water pressure has been reached.

Minimum static head – 5m.

## 6.2 appliance operation

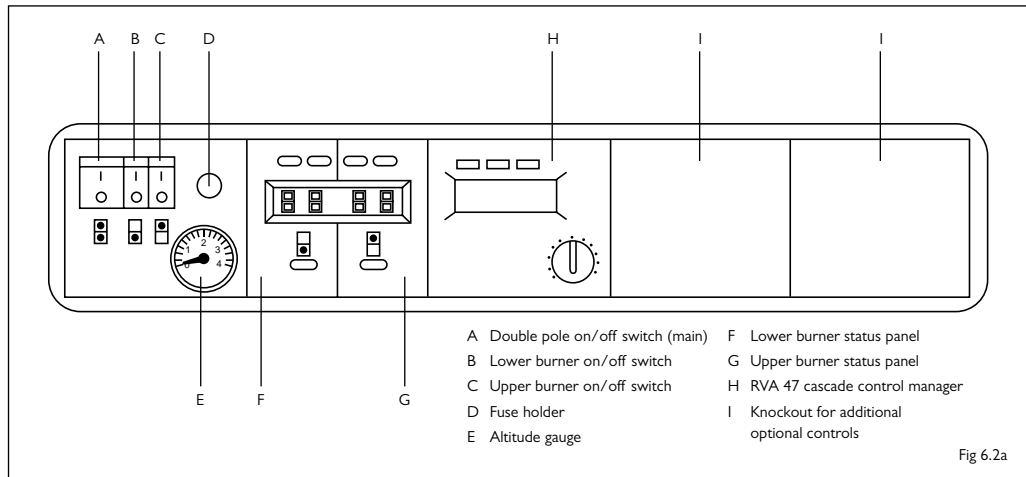

### 6.2.1 left switch panel

#### Refer to Figure 6.2a

The switch panel contains the main switch (A), this switches the entire power supply to the unity and all connected controllers on and off. The main switch also disconnects the power to all connected pumps and valves etc.

The second switch (B) only switches the lower heat exchanger on and off, allowing the upper heat exchanger to continue functioning.

The third switch (C) only switches the upper heat exchanger on and off allowing the lower heat exchanger to continue functioning.

At the right hand side is a glass fuse (D) protecting the entire unit and all connected components. This is a 6.3AT type fuse.

At the bottom of this panel is a manometer (E) which indicates the pressure in the central heating system that is connected to the boiler.

**Note:** The minimum pressure must be above 0.5 bar, while the maximum pressure is 4 bar.

### 6.2.2 module control panels

This control panel is divided into two sections, the left hand section serving the lower heat exchanger module and the right hand section which serves the upper heat exchanger module.

Each section has the following controls:

- **Reset Button** – In case of a fault, the unit can be restarted by pressing this button. In general the fault must be rectified prior to restarting.
- **Chimney Sweep Button** (Commissioning button) – Pressing this button once will activate the burner at minimum capacity (10kW). A letter 'L' will appear in the display window. Pressing this button twice will increase the capacity of the burner up to its maximum (60kW). A letter 'H' will appear in the display window. Pressing this button a third time will return the unit to its previous operating condition. If the button is not pressed a third time, the unit will fire at the chosen level for a period of 10 minutes, following which it will revert to auto operation.
- **Test Button** – Pressing this button will stop the unit burning. Releasing the button will allow the unit to restart again after a short time. The purpose of this button is to provide a simple method of testing the start-up behaviour of the unit and to test the safety circuit.

**Note:** If the unit does not switch off, the wiring harness must be checked for short circuits, or the maximum thermostat or the printed circuit of the burner must be replaced.

- **Display** – The display will always show one of the following situations.  
Supply Temperature

Operating messages:- these are always indicated by one digit

Faults:- these are always indicated by two flashing digits

If there are no faults present in the unit, the display will show the supply temperature. When the burner is firing and functioning properly, a 'dot' is shown beside the supply temperature – indicating a correct rectification signal.

## 6.2.3 DIP switches

The unit has a number of DIP switches that must always be set. These switches have different functions. To access the DIP switches, the cover plate over the circuit boards must be removed.

1. Remove the two fixing screws on the lower edge of the top cover panel.
  2. Slide the panel towards the front of the boiler and lift away.
  3. The DIP switches are easily accessible at the left side of each control circuit board.
- The RVA 47 must be set to the number of boilers installed on one system; in bus terms, each module has its own address number, which must be set.
  - The master RVA 47 manager is capable of controlling up to four burners, and if four burners are actually installed, four addresses must be set.
  - Subsequent RVA 47 controllers are capable of controlling 2 burners – the address must be set for each unit.
  - If only one boiler is installed, two addresses must be set.
  - The first four DIP switches control the PPS number allocated to the burner module.
  - To enable the master RVA 47 to control modules 3 and 4, the PPS connection between boilers 1 and 2 must be installed with the correct polarity.

The suggested numbering format for the boiler modules are as follows:

**Table 7**

Boiler with control fitted	Left Circuit Board	Lower Module Number 1
	Right Circuit Board	Upper Module Number 2
Boiler without control module	Left Circuit Board	Lower Module Number 3
	Right Circuit Board	Upper Module Number 4
Subsequent boilers with control fitted	Left Circuit Board	Lower Module Number 1
	Right Circuit Board	Upper Module Number 2

**Table 8**  
**DIP Switches 1-4**

Module Number 1	On	Off	On	On	Known as PPS #4
Module Number 2	On	Off	On	Off	Known as PPS #5
Module Number 3	On	Off	Off	On	Known as PPS #6
Module Number 4	On	Off	Off	Off	Known as PPS #7

If the unit is converted to liquid gas, DIP switch 8 must be set to ON; this automatically lowers the maximum speed of the combustion fan, to obtain the required capacity.

If the unit is fitted with Grundfos Pumps DIP switch 5 should be switched on, to allow the pumps to modulate. If modulation is not required DIP switch 5 should be switched off.

If the RAV 47 has malfunctioned, DIP switch 6 may be switched to ON, as an emergency measure, after which the unit will be kept at a steady 70°C, independent of the heat demand. When the replacement controller has been installed, DIP switch 6 must be set to OFF again.

## 6.3 firing the appliance

At the time of starting the appliance, the working gas pressure must be measured:

- The inlet working gas pressure must be measured at the inlet test nipple of the gas control valve. (see fig 6.4a).
- Nominal pressure should be 20 mbar for the Natural gas and 37 mbar for LPG (Propane).

### 6.3.1 initial start up

Ensuring that the installation has been fully tested and having found everything in order, power can be applied to the unit by switching the main switch (fig 6.2a) to the ON position. Now place the switch for the lower module in the ON position. To be independent from the heat demand from the installation, press the 'Chimney Sweep' button ONCE. The lower burner should ignite. If the appliance fails to start up, first check whether all gas taps, including the one on the unit have been opened.

Electrically, there is fourfold start-up procedure, after which a fault is reported (by flashing warning on the status display); press the RESET button for additional start up attempts. If the unit fails to start up correctly, the adjustment screw (2) (see fig 6.4a) on the gas valve must be turned clockwise  $\frac{1}{4}$  turn, and then attempt to restart the appliance.

**Note:** If the display fails to show a figure, the RESET button should be pressed.

The start-up cycle has the following stages:

- The combustion fan carries out an initial speed test at low speed – after which it will immediately switch to:
- Start Speed; when this has been reached, the gas valve will open and the unit will start up at 50% of its capacity.
- The safety time is 5 seconds, after which there is a stabilisation period for the flames, also lasting 5 seconds; this is followed by the units output being controlled via the RVA 47 cascade manager.

## 6.4 setting and adjusting the load

For checking purposes, or after installing a new gas control valve, there are two methods for setting the correct load.

- By measuring the CO<sub>2</sub> percentage.
- Checking by means of the gas rate measuring method.

Emissions must be measured in the opening, in the upper front right of the heat exchanger module, by first removing the test point cap. Refit test point cap when emissions checks have been completed.

**Table 9**  
**Unit Settings**

Type of Gas	Natural Gas G20	Propane Gas
Wobbe (MJ/m <sup>3</sup> )	49.79	76.06
Calorific Value Gross (MJ/m <sup>3</sup> )	38.63	93.87
CO <sub>2</sub> Max Load (%)	9	11
CO <sub>2</sub> Min Load (%)	9.5	11.5

### For Natural Gas G20

Gas measuring method:

- Maximum load per Heat Exchanger – 213ft<sup>3</sup>/hour.
- Minimum load per Heat Exchanger – 42.6ft<sup>3</sup>/hour.

**Note:** Values measured at a boiler water temperature of circa 60°C.

## 6.4.1 setting minimum load

To set the minimum load refer to figure 6.4a and follow the instructions below:

- Press the 'Chimney Sweep' button once, the letter 'L' will appear in the display and the unit will commence operation at minimum capacity, for up to 10 minutes.
- Check the combustion figures with those stated above.
- If the CO<sub>2</sub> content is below the stated figure, increase the gas throughput by turning the adjusting screw (2) clockwise.
- If the CO<sub>2</sub> content is above the stated figure, decrease the gas throughput by turning the adjusting screw (2) counter-clockwise.

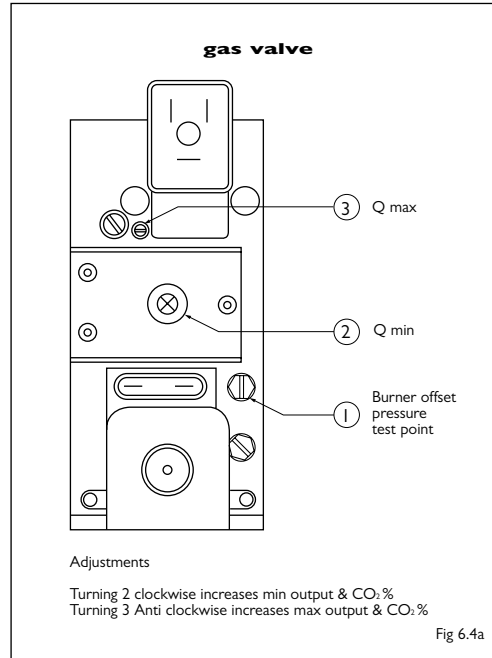

## 6.4.2 setting maximum load

The correct CO<sub>2</sub> combustion on low fire should now have been achieved. To set the maximum load:

- Press the 'Chimney Sweep' button a second time, the letter 'H' will appear in the display and the unit will begin to operate at maximum capacity.

Again check the combustion figures.

- If the CO<sub>2</sub> content is below the stated figure, increase the gas throughput by turning the adjusting screw (3) counter-clockwise.
- If the CO<sub>2</sub> content is above the stated figure decrease the gas throughput by turning the adjusting screw (3) clockwise.
- Pressing the 'Chimney Sweep' button a third time will return the unit to automatic mode, and the display will show the flow temperature.

**Note:** Adjusting the high fire, has a marked effect on the low fire figures, whereas adjusting the low fire has little effect on the high fire figures.

It is therefore suggested that once the initial set-up has been carried out, a check is made of the two settings before returning the unit to complete automatic operation.

## 6.4.3 setting maximum/minimum load for upper module

Repeat operations described in 6.4.1 and 6.4.2 – but applied to the upper module.

## 6.5 setting for propane gas

To set the unit for propane gas, complete the following steps:

- Disassemble the gas pipe between the gas valve and the gas air pipe.
- Install a propane nozzle with a diameter of 7mm on the outlet of the gas valve.
- Reconnect the gas pipe.

To obtain the correct capacity, the combustion fan speed must be adapted for propane gas, by placing the DIP switch 8 in the ON position.

## 6.6 setting domestic hot water

The RVA 47 cascade manager can be set to control the temperature of the DHW either by means of a dedicated sensor or thermostat.

## 6.7 switching off the appliance

It is recommended to leave the appliance running throughout the year in order to prevent the unit from freezing, or moving parts from becoming blocked by corrosion. In order to avoid this, set the RVA 47 controller to the 'standby' position. ⏻

In this mode, the central heating unit will run the attached pumps for 1 minute in every 24 hours, while the frost protection may remain operative.

# 7.0 boiler *control settings*

Consult the descriptions provided with the various Seimens (Landis Steafa) control units, for full instructions on application and usage. In the absence of full control instructions the following abridged instructions will be useful.

## 7.1 end user parameter settings

- To enter the End User Parameter Program, the door on the RVA 47 must be opened and one of the UP or DOWN prog buttons must be depressed.
- A number between 1 and 50 will appear in a bracket on the left of the display window. These can be paged through by using the UP or DOWN buttons.
- To alter or input the required data in the selected program line # use the + or – buttons.
- To leave the End User Parameter Setting Menu press the AUTO button.
- The defaults indicated below are for standard systems. If additional control features are required alteration will have to be made. Please refer to the RVA 47 manual for additional details.
- #, –, --- Indicates where an input can be made if required.
- -- Indicates where an input cannot be made and a sensed/attenuated figure is displayed. 'OFF' will be displayed if the +/- buttons are used.

**Table 10**

(Prog#)	Description of Prog #	Range	Inputs	Preset
<b>Time of Day</b>				
1	Time of day	0-23:59	Hr/Min	00:00
2	Weekday	1...7	Day	1
<b>Time Switch Program Heating</b>				
5	Every day the same Every day different	1-7 1...7	Day Day	–
6	1st On time	-24:00	Hr/Min	06:00
7	1st On time	-24:00	Hr/Min	22:00
8	2nd On time	-24:00	Hr/Min	–
9	2nd On time	-24:00	Hr/Min	–
10	3rd On time	-24:00	Hr/Min	–
11	3rd On time	-24:00	Hr/Min	–
<b>Hot Water Service</b>				
13	Required DHW temperature	40-60	°C	55
<b>Heating Circuit</b>				
14	Night set back temperature	10-30	°C	16
15	Frost protection temperature	4-15	°C	10
16	Summer/winter switching	8-30	°C	17
17	Slope of heating curve	-/2.5.40	°C	32

## 7.1 end user parameter settings (contd)

**Table 10**

(Prog#)	Description of Prog #	Range	Inputs	Preset
<b>Actual Values</b>				
18	Actual room temperature			--
19	Actual outside temperature (Pressing the + and – buttons simultaneously until the display stops flashing will reset the averaged value)	-50, +50	°C	--
<b>Maintenance</b>				
23	Restore factory presets Press + and – together for 3 seconds	0/1	–	0
<b>Time Switch Program DHW</b>				
29	Every day the same Every day different	1-7 1...7	Day Day	--
30	1st Ontime	-24:00	Hr/Min	06:00
31	1st Ontime	-24:00	Hr/Min	22:00
32	1st Ontime	-24:00	Hr/Min	--
33	1st Ontime	-24:00	Hr/Min	--
34	1st Ontime	-24:00	Hr/Min	--
35	1st Ontime	-24:00	Hr/Min	--
<b>Service Indications</b>				
49	Module error code (Not always displayed)	1..4/0..255		--
50	Indication of faults	0...255		--

## 7.2 heating engineer parameter setting

- To enter the Heating Engineer Parameter Program, the door on the RVA 47 must be opened and the UP and DOWN Prog buttons must be depressed for at least 3 seconds until #51 appears in the window.
- A # between 51 and 173 will appear in a bracket on the left of the display window. These can be paged through by using the UP and DOWN buttons.
- To alter or input the required data in the selected program line # use the + or – buttons.
- To leave the Heating Engineer Parameter Setting Menu press the AUTO button.

## 7.2 heating engineer parameter setting (contd)

**Table 11**

(Prog#)	Description of Prog#	Range	Preffered Setting
<b>Service Values</b>			
51	Output test 0 Automatic control 1 All outputs off 2 DHW pump/valve on 3 Circulating pump on	0...3	0
52	Input test 0 Return temperature value 1 DHW temperature value 2 Flow temperature value 3 Outside temperature value 4 Room temperature value 5 0-10 V equiv. Temp	0.5	0
53	Plant Type # refer to drawings at rear of manual *	27...36	--
54	Display of PPS communication details	1..12/0255	
<b>Actual Values</b>			
55	Actual value of module temperature	1..4/0..140	--
56	Actual value of system flow temperature	0...140	--
57	Actual value of system return temperature	0...140	--
58	Actual value of Buffer temperature	0...140	--
59	Actual value of DHW temperature	0...140	--
60	Attenuated outside air temperature	-50..+50	--
61	Comp outside air temperature	--/--	--
62	Outside air temperature source	00.01/14.16	--
<b>RVA 47 Dictated Set Points</b>			
65	Maximum flow module temperature	1..4/0..140	---
66	Maximum system flow temperature affected by external inputs	8-85	--
69	Display DHW temperature possible when operating	8-85	--
70	Nominal room temperature set point	0.0/35.0	--
71	Set point of room temperature	0.0/35.0	--
72	Display of flow temperature set point	0...140	--
<b>Heat Generation Values</b>			
75	Modules available in cascade	00.1/16.3	---
76	Lead module in cascade	00.1/16.3	--
77	Hours to run prior to sequence change	0.990	--
80	Module #1 total operating hours	0.65535	--
81	Module #2 total operating hours	0.65535	--
82	Module #3 total operating hours	0.65535	--
83	Module #4 total operating hours	0.65535	--
90	Minimum system water temperature (not always displayed)	0..95	--
91	Maximum output of module #1	0-255	55
92	Maximum output of module #2	0-255	55
93	Maximum output of module #3	0-255	55
94	Maximum output of module #4	0-255	55
<b>Configuration of Plant</b>			
95	HKP pump output function 1 Pump operates as internal pump 2 Pump operates heating pump only 3 Pump operates as primary loop pump 4 Pump operates as DHW pump 5 Pump operates as HI pump	1...5	2
97	Operation of RFO sensor 1 Sensor used for return temperature 2 Sensor used for buffer tank temperature	1..2	1

\* = Full controls equipment manual

## 7.2 heating engineer parameter setting (contd)

**Table 11**

(Prog#)	Description of Prog#	Range	Preffered Setting
<b>Space Heating</b>			
I00	Displacement of heating curve	-4.5..+4.5	0
I01	Gain factor for room temperature influence 0 Active 1 Inactive	0..1	1
I02	Room temperature pump switching differential Higher = Less stable temperature Lower = More stable temperature	-- -/0.5..4	0.0
I03	Minimum limitation of flow temperature	8...95	8
I04	Maximum limitation of system flow temperature	8...95	82
I05	Type of build construction 0 Heavy 1 Light	0/1	1
I06	Adaption of heating curve 0 Inactive 1 Active	0/1	1
<b>DHW</b>			
I20	Reduced DHW set point	8-70	40
I21	DHW time control 0 24 hours per day 1 As heating times with 1 hour shift 2 As DHW time settings	0..2	1
I22	Pump operation 0 Heating timeswitch settings apply 1 DHW timeswitch settings apply	0..1	1
I23	DHW control in cascade system 0 Controlled via master RVA 47 1 Controlled via all RVA 47s in segment 2 Controlled via all RVA 47s in LPB system	0..2	2
I24	DHW charging cycles per 24 hour period 0 One per day with 2.5 hour forward shift 1 Several per day with 1 hour forward shift	0..1	1
I25	DHW sensor type 0 Sensor 1 Thermostat switch	0..1	0
I26	Flow temperature boost in DHW mode	0..30	20
I27	DHW Priority/Shifting 0 Absolute priority 1 Shifting priority heating reduced to increase recovery on DHW 2 No priority DHW and heating operate 3 Shifting/Absolute heating switched off, mixing circuit decreased to increase recovery of DHW.	0...3	1
I29	DHW reduced set point priority 0 No, heat taken from heating circuit to increase DHW temperature 1 Yes, DHW boosted in isolation.	0..1	1
<b>Cascade Settings</b>			
I30	Hours run prior to sequence rotation	10.990	100
I31	Rotation sequence program 0 No exemptions 1 The first module is exempt 2 The last module is exempt 3 The first and last modules are exempt	0..3	0
I32	Lead module fixed/sequenced. Allows one module to be lead unit	00.1...16.3	---
I33	Cascade delay time	1..120	2
I34	Anti cycling time	0..1800	180

## 7.2 heating engineer parameter setting (contd)

**Table 11**

(Prog#)	Description of Prog#	Range	Preffered Setting
<b>LPB communication setting</b>			
140	LPB control device address 0 Standalone single RVA 47 1 Master RVA 47 cascade manager with sensors attached 2...16 Slave RVA 47s operating from master RVA 47 (ie House No.) (Each subsequent RVA 47 should be given consecutive numbers)	0..16	1
141	LPB control segment address 0 Heat generator (ie Street name) 1....14 Heat consumer	0..14	0
142	LPB Bus power supply 0 Off 1 On	0..1	1
143	Operation of LPB power supply	On/Off	--
144	Display of LPB communication	On/Off	--
145	Change over via LPB connection 0 All controllers in same segment 1 All controllers in LPB system	0..1	1
146	Summer/Winter change over function 0 Local control only 1 Entire control via LPB	0..1	0
147	Central Standby switching 0 Deactivated 1 Activated	0..1	0
148	Clock mode 0 Autonomous Clock Individual controller can have different times 1 System time, time will match system cannot be adjusted 2 Systems time with adjustment 3 System clock, master. There can only be one master on system	0..3	2
<b>Input HI</b>			
170	Operation of HI terminals 0 Changeover of operation when switch is made. (DHW stopped) 1 Changeover of operation when switch is made. (DHW released) 2 Minimum flow temperature maintained (set at 171) 3 Heat generation stopped when switch is made. (Frost Active) 4 0-10 Volt control to vary flow temperature. (Curve set at 172)	0..4	0
171	Minimum temperature set point for HI	8..95	80
172	Maximum temperature set point for HI	5...130	82
173	Operating action of HI control contacts 0 The contact is normally closed 1 The contact is normally open	0..1	1
<p>The RVA 47 will operate according to its internal time switches and presets. If a remote BMS is controlling the RVA 47 via a Volt Free switch across HI '0' should be inserted. This will allow the boilers to operate when the Volt Free switch is made and stopped (blocked), when the switch is opened.</p> <p>If you are controlling the lead (master) RVA/Boiler via a volt free switch across HI, all slave modules should be left with '1' as the input. This will allow the AUTO light and the OFF light to indicate their operational mode dictated by the lead (master) RVA/Boiler.</p>			

## 7.3 OEM parameter setting

- To enter the OEM Parameter Program, the door of the RVA 47 must be opened and the UP and DOWN Prog buttons must be depressed for at least 10 seconds until 00000 appears in the window.
- The 00000 display must be changed to 11111 by inputting a password. The password for the RVA 47 is DOWN, DOWN, PLUS, MINUS, UP.
- A # between 2 and 92 will appear in a bracket on the left of the display window. These can be paged through by using the UP and DOWN buttons.
- To alter or input the required data in the selected program line # use the + or – buttons.
- To leave the OEM Parameter Setting Menu press the AUTO button.

**Table 12**

(Prog #)	Description of Prog #	Range	Preferred setting
<b>Heat source OEM</b>			
1	Minimum module temperature (manual operation)	8..95	8
2	Maximum module temperature (manual operation)	8..120	82
8	HKP, SLP Pump overrun timer	0..20	5
22	Minimum limitation of boiler return temperature (not always displayed)	8..95	8
25	Calibration of module #1	-100..+100	13
26	Calibration of module #2	-100..+100	13
27	Calibration of module #3	-100..+100	13
28	Calibration of module #4	-100..+100	13
<b>Space Heating OEM</b>			
30	Room influence gain factor	0..20	4
31	Quick setback constant (room sensor dependant) Increase. Setback will become longer Decrease. Setback time will become shorter	0..20	2
32	Boost of room temperature set point (room sensor dependant) Increase. Heat up time reduced Decreased. Heat up time increased	0..20	5
33	Frost protection program 0 Frost protection program switched. Off 1 Frost protection program switched. On	0..1	1
34	Over temperature pump protection 0 Deactivated 1 Activated	0..1	1
35	Heat gains Increase. If gains are high Decrease. If gains are low	-2...+4	0
36	Curve Adaptation 1 sensitivity Outside air range between 4-12°C	1...15	15
37	Curve Adaptation 2 sensitivity Outside air range below 4°C	1...15	15
<b>DHW OEM</b>			
40	Maximum DHW set point	8...80	60
41	DHW switching differential (sensor only)	0..20	5
42	Legionella protection program 0 Inactive 1 Activated (every Monday morning) (oem43)	0..1	1
43	Legionella temperature	8..95	70
44	DHS discharge protection 0 Protection not active 1 Protection active 2 Protection active when heating is locked (not always displayed)	0..2	2
<b>Cascade Setting OEM</b>			
50	Cascade management strategy 1 Automatic 2 Automatic 3 Automatic 4 Fixed 5 Fixed 6 Fixed	1...6	2

## 7.3 OEM parameter setting (contd)

**Table 12**

(Prog #)	Description of Prog #	Range	Preferred setting
51	Minimum output % reached prior to cascade switching modules Off	5..100	40
52	Maximum output % reached prior to cascade switching modules On	5..100	80
56	Time spent by module on ignition rate prior to modulation. (delay time between modules)	0..1200	0
60	Minimum temperature difference between flow and return temperature	0..20	2
<b>Configuration of Plant OEM</b>			
90	Display default 0 Day # Time of day 1 System flow temperature	0..1	0
91	Software version	00.0...99.9	--
92	RVA 47 controller operation hours	0.500,000	--

## 8.0 maintenance *and inspection*

The frequency of servicing will depend upon particular conditions and usage, however for general guidance, maintenance/inspections should take place at least every 12 months. Prior to carrying out any required maintenance, the unit must be inspected.

### 8.1 inspection

Complete the following steps before commencing inspection:

- Ask the user for any problems with the Central Heating unit or any other comments regarding the appliance.
- Check the water pressure and treatment level of the installation.
- Remove the casing of the unit and inspect all pipes and connections for water leaks.
- Open the syphon rinsing pipe at the back of the boiler.
- Run the unit at maximum capacity and measure the load or the CO<sub>2</sub>.
- Run the unit at minimum capacity and measure the load or the CO<sub>2</sub>.
- Listen to the sound of the module pump.
- Disassemble the burner by removing the six M6 bolts, removing the ignition cable and disassembling the two combustion fan cables.
- Inspect the combustion fan blades.
- Check the spark between the electrode and the burner – this should be between 5 and 6mm.
- Check the interior of the heat exchanger for any contamination.

## 8.2 maintenance

Any maintenance must be carried out as a result of faults noted in the inspection. Remarks and comments made by clients must be considered and the causes of any faults or problems must be found.

**Note:** The pressure of the installation must be not less than 0.5 bar, any leakage within the system will affect the pressure and so must be identified.

If the module pump makes an un-natural noise, and in particular if the pump is more than 5 years old, the pump should be replaced by way of preventative action.

If the interior of the heat exchanger is contaminated and/or there is a deposit on the stainless steel pipes, the latter must be removed with a hand brush or citric acid (do not use a steel brush). Remove any dirt created with a vacuum cleaner.

**Note:** Never clean the burner itself.

The Condense syphon must be rinsed. This can be done by removing the burner and using a filling hose, insert water into the heat exchanger, which will automatically reach the syphon.

If dirt has deposited on the combustion fan blades, each blade must be carefully cleaned, until the blade material is visible again. If this is not done evenly, the combustion fan will rotate out of balance.

## 9.0 fault *diagnosis*

### 9.1 control panel

The control panel is divided into two sections, the left hand section serves the lower heat exchanger and the right hand section serves the upper heat exchanger.

The two digital displays provide the following information regarding the functioning of the Strata 2-120:

Normal operating situations, the display always shows the flow temperature of the boiler water.

Operating messages, which are always indicated by one digit.

Fault messages, which are always indicated by flashing two digits.

System faults in the FMT 310 module control unit.

#### 9.1.1 operation indicator

An operating message means that the burner of the heat exchanger concerned is not operational, the reason being reported in the operating message. If this situation has resolved itself after some time, the unit will automatically restart.

##### **0. Unit prevented from operating. Styphon monitoring active.**

If the water level in the syphon has dropped, the unit will automatically restart.

##### **1. Unit prevented from operating. Water temperature too high, measured by the boiler thermostat.**

If the water temperature drops by more than 20°C within 30 seconds, the unit will start to operate, if this is not the case, the unit will lock out.

OR

##### **1. Unit prevented from operating. Condensate syphon overflow.**

If the condensate produced by the unit is not allowed to pass from the unit to a suitable drain point the level switch located in the base of the flue gas tube will activate and prevent the unit from operating.

## 9.1.1 operation indicator (contd)

### 2. Unit prevented from operating. Water temperature too high, measured by the flow sensor.

When the water temperature drops by more than 20°C the unit will start to operate.

### 3. Unit prevented from operating. Anti-cycling time.

When the anti-cycling time (3 minutes has expired, the unit will automatically fire up again).

### 5. Unit prevented from operating. Combustion fan speed too high.

The combustion fan has been switched off, but a speed indication is still detected. The Strata 1-120 will be blocked and after 3 minutes, a locking (flashing) fault will be shown with the same text. If, however, the situation is resolved within 3 minutes, the unit will return to normal operating mode.

### 7. Unit prevented from operating. Combustion fan speed too low.

If this code appears, the Strata 1-120 will be blocked. If the speed has not returned to the normal value within 3 minutes, locking will take place. If the situation is resolved within this period, the unit will resume normal operation.

### 8. Unit prevented from operating. Flame simulation.

Although the burner is not operative, a possible flame is being detected. If this code is shown, the burner control will be blocked. After five seconds, the burner control will be locked.

### 9. Unit prevented from operating. Limit temperature flue gases.

If the flue gas temperature drops by more than 20°C, the unit will automatically fire up again, if this is not the case, the unit will lock out.

### da Communication between burner control and RVA 27 interrupted (PPS).

The burner in question will not operate until the circuit is re-established - check all PPS wiring connections for security. Apply contact cleaner to all PPS connections. Check voltage on PPS connections should be 10-15vdc.

### db Communication between burner control and the ignition control board interrupted.

The burner in question will not operate until the circuit is re-established.

## 9.1.2 fault indicator (flashing)

The unit automatically makes several attempts to resolve any malfunctions in the system, if these attempts prove unsuccessful the unit is switched off. The fault is indicated by means of a flashing code.

The type of fault is indicated by a two digit code, the first digit shows when the fault occurs, the second digit shows the nature of the fault. This means that any combination of digits may show, but some combinations will never occur.

Refer to the tables below for fault types:

**Table 13**  
**First Digit**

1.	System Test
2.	Stand by
3.	Pre Purge
4.	Pre Ignition
5.	Ignition
6.	Operation
7.	Post Purge

**Table 14**  
**Second Digit**

1.	Maximum thermostat open, or water level in syphon too high
2.	Flue gas thermostat open
3.	Resistance in the flue gas tube is too high
4.	Unused figure
5.	Combustion fan speed too low
6.	Combustion fan speed too high
7.	No flame signal

For example, if the flashing fault code 6 7 appears, this means that the flame has disappeared several times during operation.

## 9.1.3 system faults

These faults are indicated with a letter, occasionally followed by a number. To avoid confusion in the indication, the letters and numbers are fixed as follows:

**Table 15**

E1	Fault with flow sensor
E2	Fault with cable for gas valve or gas valve coil
E3	Fault with rectification circuit
E4	Burner control circuit board has a fault
--	Communication via RS232 connection possible
E5	Parameter fault
E6	Communication fault

## 9.2 RVA 47 Fault Indication

- If the sensor or burner modules connected to the RVA 47 controller fail or are removed from the circuit, an error message will be displayed on the left of the LCD screen.
- Error Message Notation ER
- Once an error message is present the cause of the error can be traced by accessing function (50).
- To access function (50), open the flap of the controller and press down arrow button twice. (50) should appear in the left-hand side of the LCD display.
- The figure shown in the centre of the screen is the fault identification number. The display can hold a number of faults but will only display 2 at any one time. The second error can be accessed by pressing the + or – buttons.
- Once a fault has been rectified the error number will disappear or be replaced with another fault number if further attention is required.

The fault identification numbers are detailed below:

**Table 16**

Blank	No Fault
10	Outside air temperature sensor
26	System flow temperature sensor
46	Boiler circuit return temperature sensor
50	DHW temperature sensor
58	DHW control thermostat
61	Fault room unit
81	Short circuit on LPB connection
82	Address conflict on LPB circuit
86	Short circuit on PPS connection
100	Two clock masters present
145	Wrong device connected
146	Unrecognisable plant configuration
147	No burner module connected
150	General burner module fault

## 10.0 parts list

The Parts List is for service purposes. If no numbers have been listed, the parts concerned are non serviceable parts.

Short spaces parts list:

Description of Part	Part Number
Water temperature sensor	252014
Limit thermostat	250083
Fan	252013
Pump	130160
Gas valve	251166
Ignition electrode	251095
Ignition transformer	252033
Control PCB, Fmt 310	252032
Fuse 6.3A 250V	252037
Manometer 0-4 bar	252027
O-ring set	O-ring kit

## 11.0 guarantees

- The boiler body and exhaust system both carry a five year material guarantee.
- The burners and all electrical components and other component parts carry a one year guarantee.
- The guarantee starts at the day of delivery.
- This guarantee only applies if regular maintenance has been carried out.
- In addition, no guarantee is made for damages which have arisen from:
  - Unsuitable and inappropriate utilisation.
  - Erroneous assembly and/or start of operation by unqualified persons.
  - Operational wear.
  - Erroneous or careless treatment.
  - Incorrect burner adjustment.
  - Lack of, or unsuitable water treatment additives.
  - Non-observance of the installation, start of operation and maintenance instructions
  - Inappropriate changes or repair works carried out by the customer or third parties.
  - Contaminated combustion air.
  - Waterside contamination (fouling, scaling etc).

# STRATA2



A member of the Modular Heating Group Plc

35 Nobel Square, Burnt Mills Industrial Estate, Basildon, Essex SS13 1LT Tel: 01268 591010 Fax: 01268 728202  
<http://www.modular-heating-group.co.uk>

This publication is issued subject to alteration or withdrawal without notice.  
The illustrations and specifications are not binding in detail. All offers and sales are subject to the Company's current terms and conditions of sale.